

# Guide-Light™ Installation Guide

## GUIDE-LIGHT™ MODELS GL1100/1101/1102/1103

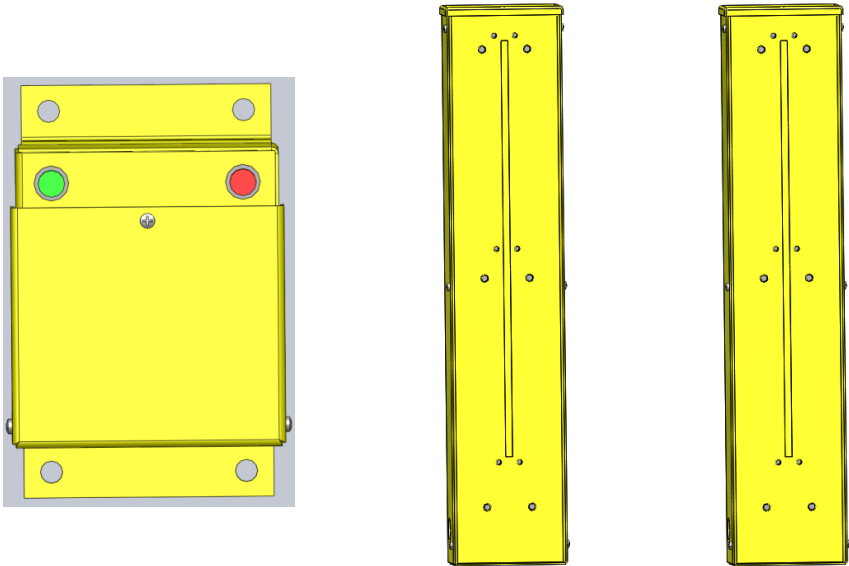

340 Gateway Park Drive  
North Syracuse, NY 13212  
Phone: 315-463-7348  
Toll Free: 866-235-7468  
Fax: 315-463-8559  
Email:  
sales@dlmanufacturing.com  
www.dlmanufacturing.com

# Guide-Light™ Installation Guide

## Table of Contents

Page 1 :	Electrical Ratings, Installer Supplied Tools, Warnings
Page 2 :	Locating and Mounting the Inside Power Box
Page 3:	Locating and Mounting the Outside light Boxes
Page 4:	Photo-eye or Wobble Switch Mounting for Sectional Doors
Page 5:	Photo-eye or Wobble Switch Mounting for Rolling Steel Doors
Page 6:	Wiring Schematic for GL1100 (Yellow only)
Page 7:	Wiring Schematic for GL1101/GL1102 (Wobble Switch/Photo-eye)
Page 8:	Wiring Schematic for GL1103 (Application with a Smart Chock or Safety Signal)
Page 9:	Warranty

Models	
GL1100	Yellow
GL1101	Red/Green with wobble switch
GL1102	Red/Green with Photo-Eye
GL1103	Add on kit to DL Manufacturing Safety Signal or Smart Chock

Electrical Ratings	
INPUT VOLTAGE	77-277 VAC
INPUT FREQUENCY	50-60 HZ
MAXIMUM INPUT CURRENT	0.05 amp
OUTSIDE LIGHT BOX VOLTAGE	12 VDC
MAXIMUM OUTSIDE LIGHT BOX LOAD CURRENT	1.25 A (12 V POWER SUPPLY CURRENT LIMIT)
SENSOR VOLTAGE (Photo-eye)	12 VDC
MAXIMUM SENSOR CURRENT (Photo-eye)	.2 A

Installer Supplied Tools	
<input type="checkbox"/> Tape Measure	<input type="checkbox"/> Small Screwdriver
<input type="checkbox"/> Utility Knife	<input type="checkbox"/> Small Screwdriver
<input type="checkbox"/> Wire cutter/strippers	

**Installers should completely review this manual prior to starting. Please use extreme caution and proper safety procedures when working around loading docks and levelers. Refer to leveler manufacturer's Owners Manual prior to starting for proper safety procedures.**

# Guide-Light™ Installation Guide

## Locating and mounting the Inside Box Models (GL1100/GL1101/GL1102)

1. The inside power should be mounted on the left side of the door opening. Using tapcons.
2. Connect the appropriate power.
3. Using rigid conduit, connect the inside power box the outside light box shown in Figure 2. **NOTE: The outside light boxes are arranged as a mother daughter board configuration. Make sure the conduit from the inside power box goes to the mother board typically on the right side when looking at the dock from the outside.**
4. Run 2 to 7 conductors to the outside light box depending upon which model is being installed.

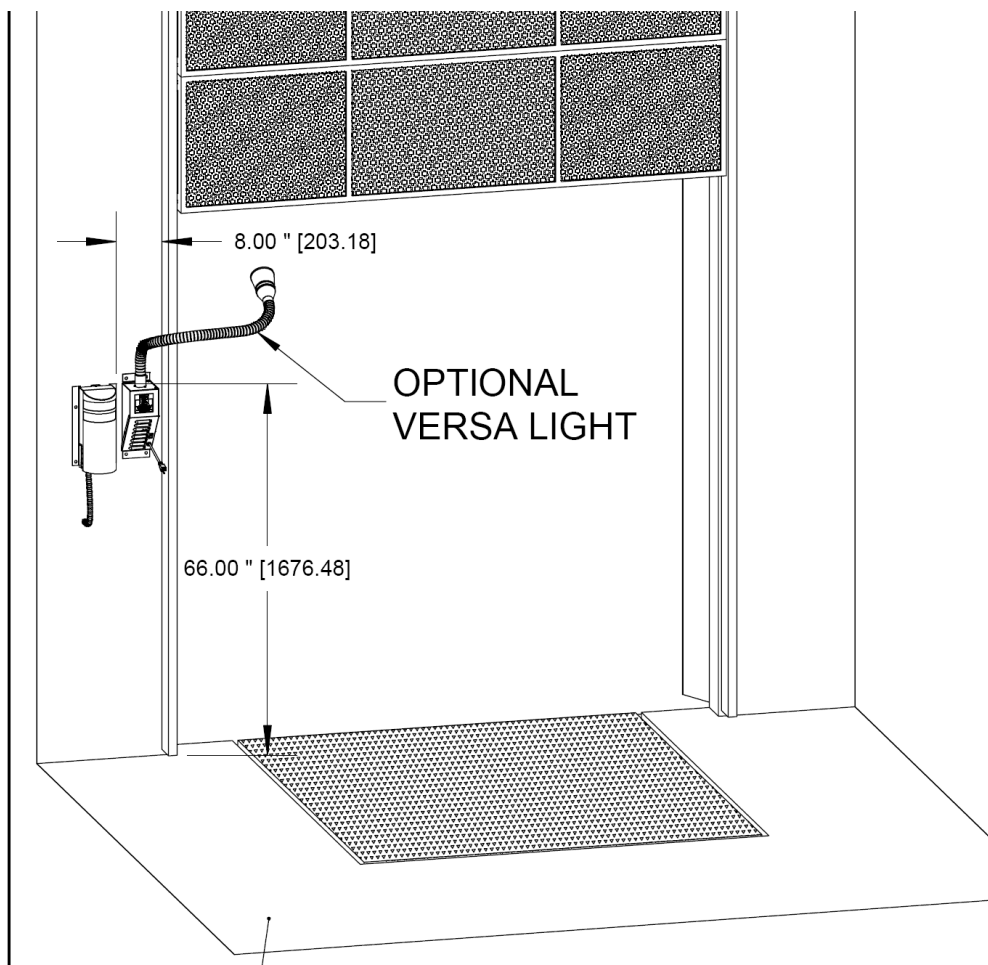

Figure 1. Inside Power Box

# Guide-Light™ Installation Guide

## Locating and mounting the outside light boxes (all models)

1. The outside light boxes should be centered and mounted on either side of the dock. The boxes should be placed so that they do not interfere with dock bumpers leveler and seals.
2. Using concrete anchors or large tapcons mount the outside boxes as shown in Figure 2.
3. Connect the two boxes using rigid conduit, making sure that it is securely fastened to the wall and does not interfere with the dock leveler operation.
4. Run four conductors between the boxes and terminate.

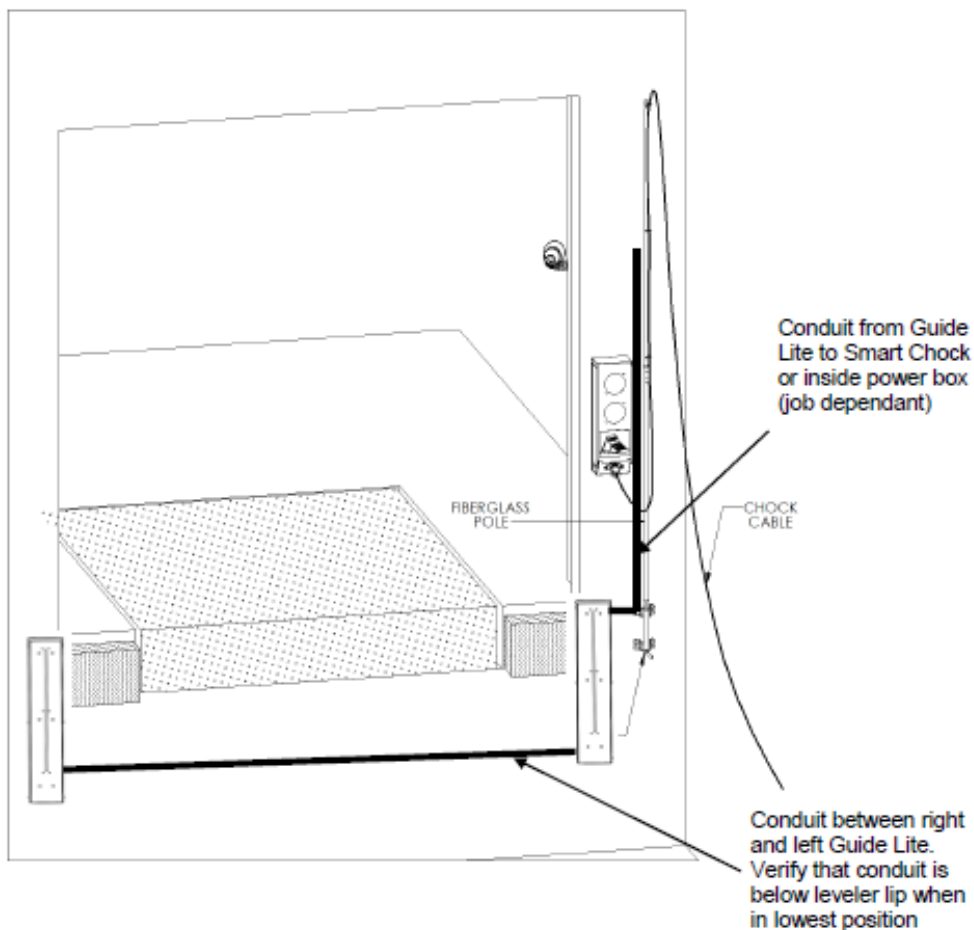
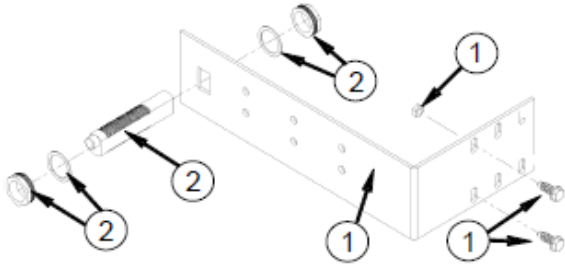

Figure 2. Outside Light Boxes

# Guide-Light™ Installation Guide

## PHOTO EYE/WOBBLE SWITCH MOUNTING KIT

(FOR TYPICAL LOCATIONS & MxV DOORS)



### STEP 1

MEASURE 18" ABOVE THE DOOR (START AT THE TOP OF DOOR JAMB) TO INSTALL PHOTO SENSOR

### STEP 2

DRILL 2 HOLES IN ROLLER TRACK. USE 17/64" DRILL BIT  
REFER TO PAGE 7 FOR MOUNTING INSTRUCTIONS

### NOTE:

PHOTO SENSOR HAS A RANGE OF 1/2" TO 3-1/2".  
2" TO 3" IS RECOMMENDED.

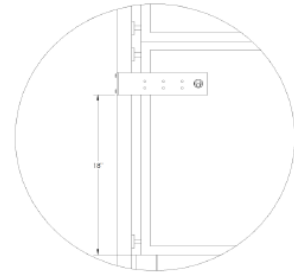
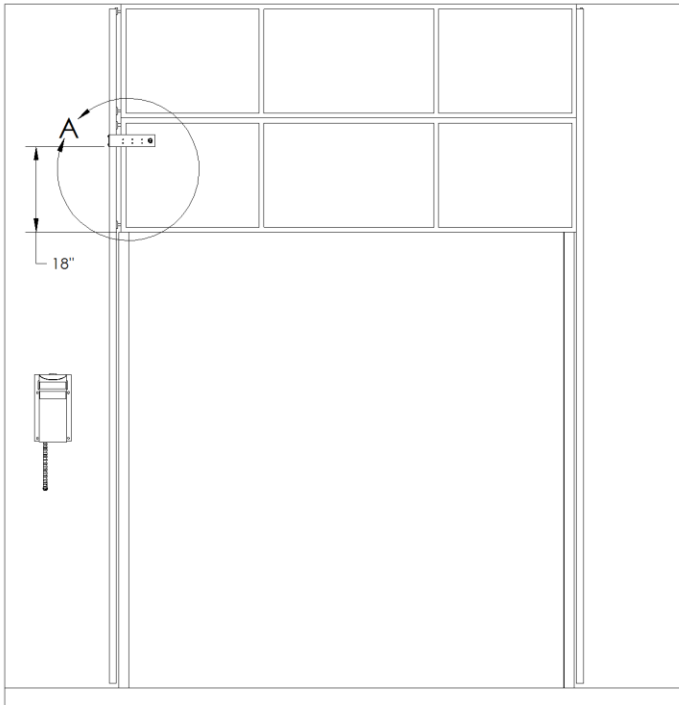

DETAIL A  
SCALE 1 :  
20

ITEM #	QTY #	PART #	DESCRIPTION
1	1	CP5016	MOUNTING BRACKET KIT
2	1	CP3268	PHOTO SENSOR KIT

## PHOTO EYE/WOBBLE SWITCH INSTALLION SECTIONAL & MxV DOORS

# Guide-Light™ Installation Guide

## PHOTO EYE/WOBBLE SWITCH MOUNTING KIT (FOR ROLLING STEEL DOOR)

### STEP 1

TO LOCATE THE MOUNTING BRACKET POSITION, OPEN THE DOOR ALL THE WAY.

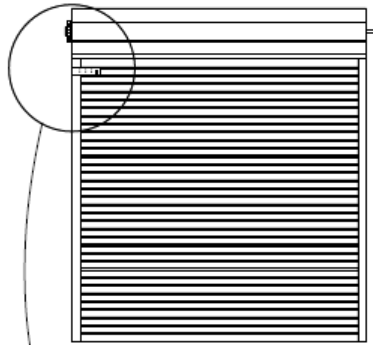

### STEP 2

POSITION THE TOP OF THE BRACKET SO THAT IT LINES UP JUST BELOW THE BOTTOM SECTION OF THE DOOR AND MARK HOLES.

### STEP 3

DRILL 2 HOLES IN ROLLER TRACK. USE 17/64" DRILL BIT.

### STEP 4

LOCATE THE PHOTO SENSOR OPERATING ADJUSTMENT (SEE FIGURE BELOW). SET THE PHOTO SENSOR FOR LIGHT OPERATE.

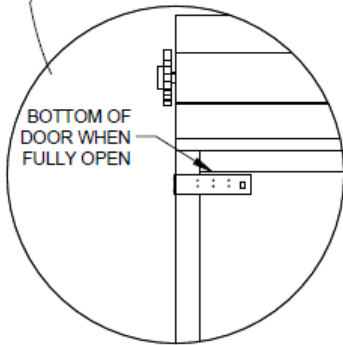

### STEP 5

ATTACH THE PHOTO SENSOR TO THE MOUNTING BRACKET USING THE NUTS AND WASHERS SUPPLIED WITH SENSOR.

### STEP 6

ATTACH THE MOUNTING BRACKET TO THE TRACK RAIL USING HARDWARE SUPPLIED WITH MOUNTING KIT.

REFER TO PAGE 11 FOR WIRING INSTRUCTIONS

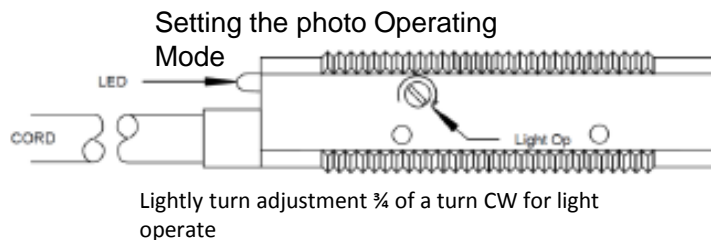

## PHOTO EYE/WOBBLE SWITCH INSTALL – ROLLING STEEL DOORS



# Guide-Light™ Installation Guide

## Wiring Schematic GL1101 (Wobble Switch)

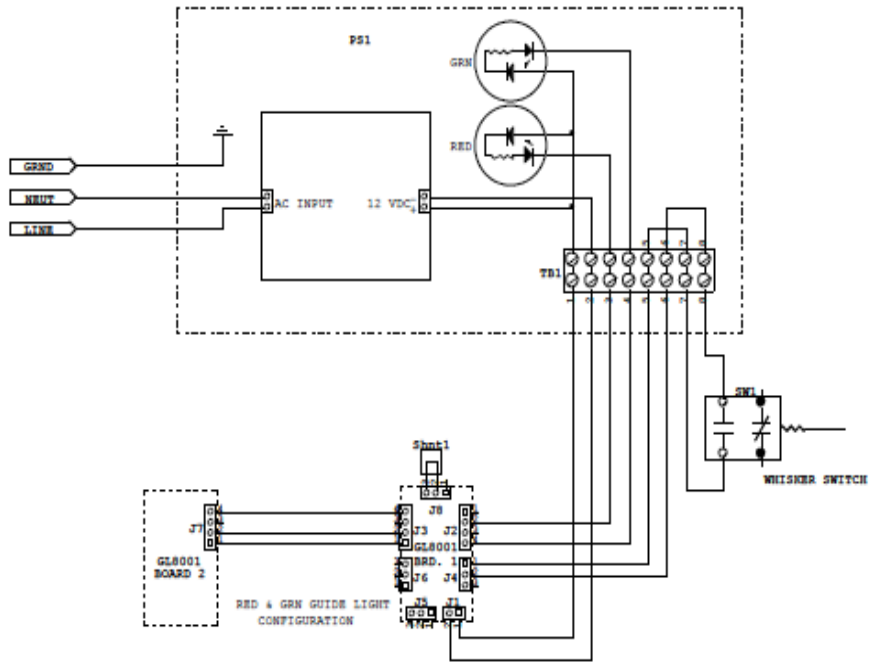

## Wiring Schematic GL1102 (Photo-eye)

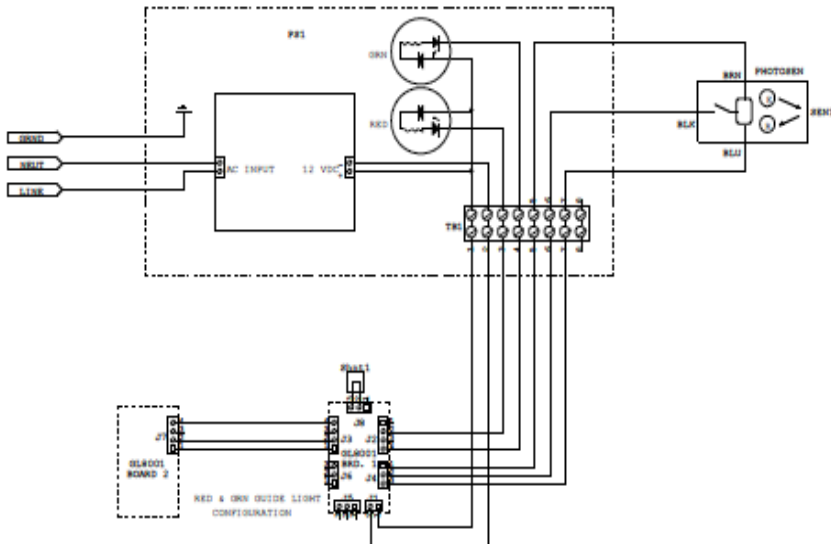



# Guide-Light™ Installation Guide

## Wiring Schematic GL1103 (Safety Signal)

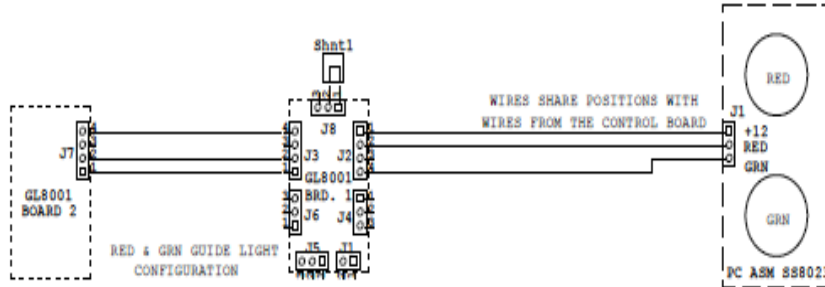

## Wiring Schematic GL1103 (Smart Chock)

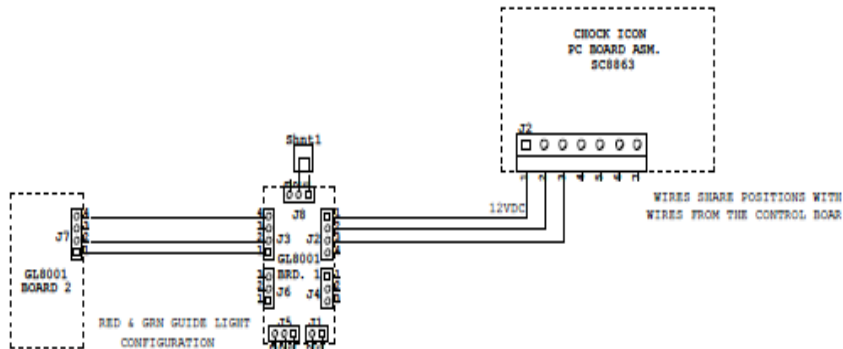

# Aero Tec™ Installation Guide

DL Manufacturing

## **Terms / Conditions/ Warranty**

### Shipping Times

- ~ Orders for stock items received by 3:00pm EST will be processed for shipment the next day. Orders requesting 2<sup>nd</sup> Day Air or Overnight Air received by 1:00pm will be processed for same day shipment.

### Shipments / Freight

- ~ All DL Manufacturing orders will ship directly from our facility in North Syracuse, NY.
- ~ All parts will be shipped via UPS Ground unless you authorize a different service. UPS shipments are prepaid and the charges are added to your invoices.
- ~ For orders shipping by common carrier, the freight will be FOB, North Syracuse, NY. When “best way” is the preferred shipping method on your order, DL Manufacturing will choose the carrier, unless otherwise stated, for the orders shipping from this facility. No adjustments will be made after the order has shipped.

### Returns

- ~ DL Manufacturing will issue a Returned Material Authorization (RMA) number for any product, parts and accessories. Products should not be returned without an RMA number.
- ~ Replacement parts will be invoiced at the time of shipping. Invoices will be credited upon receipt and inspection of Returned Material Authorization (RMA).
- ~ Freight for returns is paid for by the shipper unless otherwise specified by DL Manufacturing.
- ~ A restocking fee of 25% of net price or a minimum \$20.00 is charged for returns.
- ~ All replacement parts are warranted for a period of 90 days from shipment.

### Cancellation Fees

- ~ Cancellation charges may be incurred on orders cancelled with DL Manufacturing. Please contact DL Manufacturing to discuss each situation.

### **Warranty Policy**

- ~ All Products (excluding bulbs) manufactured by DL Manufacturing are warranted to be free from defects for a period of 12 months from the date of shipment, excluding doors, which have a warranty period of 12 months from date of installation or 18 months from shipment, whichever occurs first. This warranty does not cover unreasonable/improper use or use beyond rated conditions, improper storage, negligence or accident; damage because of incorporated use of equipment with Goods, after Customer has or reasonably should have, knowledge of any defect; or improperly installed by any other Person that is unauthorized by DL Manufacturing. This warranty is subject to customer covenants to inform all subsequent buyers of the Goods of the limitation on and exclusive of warranties provided for herein. Customer hereby indemnifies and agrees to hold DL Manufacturing harmless from and against all losses, costs and expenses, including reasonable attorney's fees incurred by DL Manufacturing as a result of any third party claim relating to the purchase, sale or use of, or otherwise relating to, the Goods covered by this Agreement. In no event shall DL Manufacturing be required to repair, replace or reimburse Customer for more than the part or material that is found to be defective and DL Manufacturing's liability shall in such event be no greater than the invoiced price of the item and shall not include labor, shipping or other costs incurred in connection with the reshipment of defective Goods to DL Manufacturing or the reinstallation of such Goods after any repair or replacement. The remedy set forth in this paragraph is expressly agreed to be the sole and exclusive remedy for any breach of warranty. This warranty is exclusive and in lieu of all other warranties expressed or implied, including but not limited to any warranty of merchantability or of fitness for a particular purpose. Limitation of Liability - In no event as a result of breach of contract, warranty or negligence shall DL Manufacturing be liable for special, or consequential damages including but not limited to loss of profits or revenues, loss of any equipment, cost of capital, cost of substitute equipment, facilities or services, downtime costs or claims of purchasers of the Customer for such damages. Additionally, DL Manufacturing will not be liable for any delay in the performance of contracts and orders, or in the shipment and delivery of goods, or for any damage suffered by the Customer by reason of delay, when such delay is, directly or indirectly, caused by force majeure, including war, Government interference, strikes, embargoes, shortage of labor, fuel, fires, floods, or any other cause or cause whether or not similar in nature to any of those herein before specified beyond DL Manufacturing's control.