

MxV™ Operating, Installation and Maintenance Guide

Vertical Doors

Models DR0800-TS-5 thru DR0808-TS-5

Models DR0800-SCW-6 thru DR0808-SCW-6



A Product of



340 Gateway Park Drive

North Syracuse, NY 13212

Phone: 315-463-7348

Toll Free: 866-235-7468

Fax: 315-463-8559

Email: sales@dlmanufacturing.com

www.dlmanufacturing.com

Table of Contents

▪ Pre-Installation Guide	
Safety Instructions.....	3
Owners Responsibilities/Things to Know Before Getting Started	4
Required Tools and Supplies/Door Operation.....	5
Approved Mounting/Welding Methods.....	6
Manufacturer-Supplied Hardware & Fasteners.....	7-8
Key Measurements.....	9
▪ Installing MxV Torsion Spring (TS) Doors	
Mounting Rails & Tracks.....	10-13
Mounting Bearing Brackets.....	14
Mounting Door Panels.....	15
Mounting Torsion Springs, Shaft and Drums.....	16-17
Installing Hold Down Bracket Asm. and Door Locks.....	18
Installing Header Seal Brush & Upper Track Seals.....	19
▪ Installing MxV Counterweight (CW) Doors	
Mounting Counterweight Bearing Brackets.....	20
Mounting Counterweight Shaft Assembly and Drums.....	21-22
Mounting Door Panels.....	23
Mounting Safety Cog.....	24
Attaching Cables, Leaf Springs, and Counterweight Tube Brackets.....	25
Counterweight Stack Installation.....	26
Mounting Counterweight Tubes.....	27
Mounting Swing Arm Assembly.....	28
Installing Hold Down Bracket Asm., Backer Plates and Door Locks.....	29
Installing Header Seal Brush & Upper Track Seals.....	30
▪ Troubleshooting, Maintenance and Warranty Information	
Final Door Installation Checklist.....	31
Door Installation Troubleshooting Guide.....	32
MxV Maintenance Procedures.....	33
DL Manufacturing Warranty.....	34

Pre-Installation Guide

□ Safety Instructions

WARNING

This symbol indicates information that, if ignored, could possibly result in personal injury or even death due to incorrect handling.

CAUTION

This symbol indicates information that, if ignored, could result possibly in personal injury or physical damage due to incorrect handling.

READ AND FOLLOW ALL OPERATION, INSTALLATION AND MAINTENANCE GUIDELINES LISTED

1. Wear protective gloves during installation to avoid possible injury from sharp metal components.
2. All installers to wear proper eye protection when using tools, otherwise injury could result.
3. Operate door only when it has been properly adjusted and is free from any obstructions.
4. If a door becomes hard to operate, inoperative or damaged, call our Service Department toll free for assistance (**1-866-235-7468**). Immediately have the necessary adjustments and/or repairs made by trained technicians using proper tools and procedures.
5. **DO NOT** stand or walk under a moving door, or permit anybody to stand or walk under an operator assisted door.
6. **DO NOT** place fingers or hands into open sectional joints, track and other door parts when opening/closing a door. Use provided lift handles when operating door manually.
7. Due to constant spring tension, do not attempt to adjust, repair or alter any part of the door, especially to torsion springs, spring brackets, fasteners, counterbalance lift cables, counterbalance weights or supports. To avoid possible injury, such work should be performed by trained technicians.
8. When installing a door with torsion springs always use properly sized solid steel winding bars.
9. On operator assisted doors, pull down ropes and locks must be either removed or placed into the unlocked position.
10. Visually inspect door and hardware monthly for any worn and or broken components. Check to ensure the door operates freely. Refer to **Page #33** for monthly pm checklist
11. Test operator assist safety features monthly, following manufacturer's instruction manual.
12. This door may not meet building codes with regards to wind load requirements in your area. For your safety, you will need to check with your local code enforcer for wind load code requirements and building permit information.
13. DL Manufacturing Company disclaims all liability for any installation which is not in compliance with applicable state, county, or local building codes.

INSTALLERS MUST FOLLOW O.S.H.A. & LOCAL SAFETY GUIDELINES!!!

□ Owners Responsibilities

1. The owner should understand and comply with all safety standards. The owner is responsible for training and adhering for all safety standards when working with DL products.
2. All posted safety instructions should be visible to all operators or staff involved with this door. No posted safety instructions shall be obscured from view.
3. Any doors that have experienced physical or structural damage, including engagement of the Safety Cog, should be immediately removed from service. Such doors need to be repaired by qualified technicians before returning to service.
4. Any special modifications made to the doors beyond what is described in this manual requires written permission from DL Manufacturing otherwise the warranty is voided.

WARNING

Installers should completely review this manual prior to starting. Please use extreme caution and proper techniques when handling springs, counterweights and associated parts to avoid injury. Only qualified professionals should install and maintain this product.

Do not store this product outside, this will void the warranty. Painting of the panels will void DL Manufacturing warranty. Direct handling of panels with forklifts or other machinery is not advised and may void the warranty.

□ Things to Know Before Getting Started

IMPORTANT!!!

Read all instructions completely before starting installation of the door. Become familiar with the components before assembling the door will reduce the installation time.

1. Adequate structural support must be provided in order to reinforce/support Bearing Brackets and Shaft Center Supports. Also, Upper and Lower Mounting Rails will need to be supported. Inspect jambs, header and mounting surface, any wood found not to be secure, must be replaced.
2. Check the opening size **Door Width x Door Height** and verify that the door provided is the proper size for the opening.
3. Check all supplied materials and hardware. Any shortages should be reported to our Service Department (**1-866-235-7468**) accompanied by contact information and job number for resolution. Report the number of pieces received along with the number of shorted items.
4. Check for adequate headroom, side clearance and projection clearance. Headroom can be best described as the distance between the top of the door opening to the lowest obstruction. Side clearance is the distance from either the left or right side of the door jamb to the nearest obstruction. Projection is the distance from the inside wall of the building toward the installer.
5. To avoid injury, and insure proper installation, it's highly recommended that you read and fully understand the complete instructions before attempting to remove any existing doors and preparing openings.

MxV™ Operating, Installation and Maintenance Guide

▣ Required Tools and Supplies

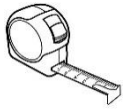

Tape Measure



Plumb Bob



Curved Jaw Vise Grip

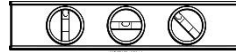

4' Long Level

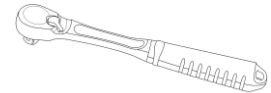

Ratchet Wrench

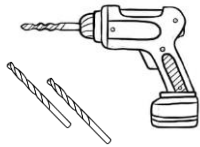

Drill with 1/4" Drill Bits



Wrenches: 3/8", 7/16", 1/2", 9/16", etc.

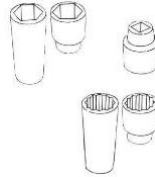

Socket Nut Driver: 3/8", 7/16", 1/2", 9/16", etc.

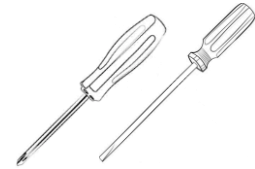

Phillips and Flat Head Screwdrivers

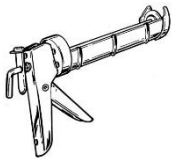

Silicone Caulk

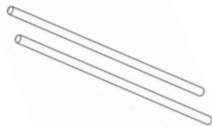

Torsion Spring Winding Bars



Safety Glasses



Multi-purpose Gloves



Various Step Ladders

▣ Door Operation (Normal Usage)

1. Employees should be trained on how to properly use the door.
2. Keep employees clear of door when in operation.
3. Using the door with excessive force may damage the door and result in injury.
4. Do not use a damaged or malfunctioning door.
5. Do not close the door with an object in the door opening.
6. Do not use fork truck to open or close a door.

SAFETY NOTE

Installers must use properly sized winding bar when winding torsion spring.

▣ Door Operation (Resetting Door)

1. Visually inspect the door at a safe distance. Make sure that there is not any physical damage before attempting to reset the door in the track.
2. Do not put hands or fingers between dislodged panels.
3. Pull panels into the space between the track and door jamb. Realign door panels by using handles to pull the displaced panels back into position.
4. Open and close the door. The brush will reset through the corrective slots.
5. If the door is knocked into the building, push all the panels through the track into the space between the track and door jamb. Then repeat Step 4.

Approved Mounting Styles – Fasteners Supplied By Others

Description	Fasteners
Hollow Concrete Block Figure A	3/8" x 1-7/8" sleeve anchor and 3/8" washer Fastenal #50305 or equivalent
Concrete Wall Figure B	3/8" x 2-1/4" wedge anchor and 3/8" washer Fastenal #52004 or equivalent
Tilt Up Panel Figure B	3/8" x 2-1/4" wedge anchor and 3/8" washer Fastenal #52004 or equivalent
Tilt Up Panel 4" Insulated Figure C	3/8" x 7" wedge anchor, 3/8" washer Fastenal #0226245 or equivalent and Ø1/2" schedule 40 black gas pipe.
Structural Steel Figure D	1/4" x 1-1/4" TEKS® #5 Screws with 1/4" x 1" Fastenal #33207 or equivalent
Wood Backed by Solid Material	3/8" x 3-3/4" anchor with 3/8" washer with Fastenal #52007 or equivalent & 3/8" x 1-1/2" lag bolts (door) Fastenal #22259 or equivalent

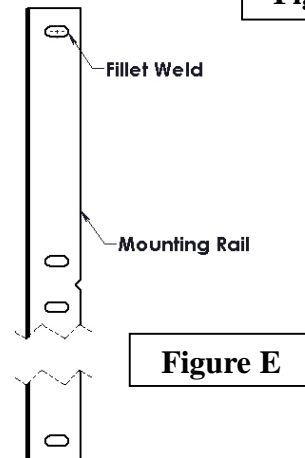
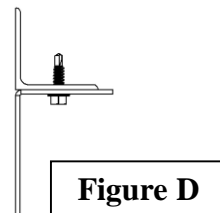
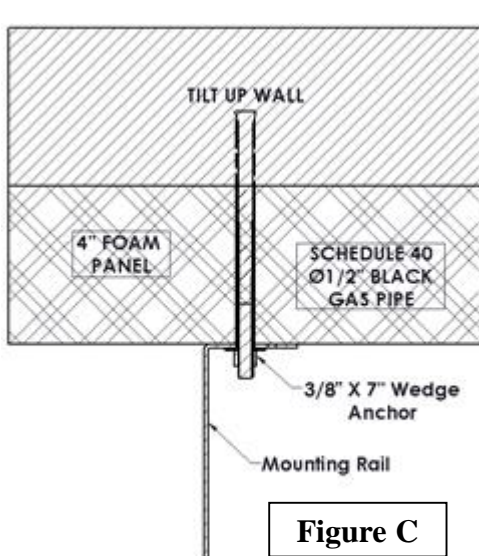
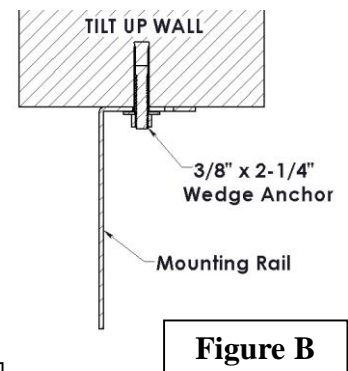
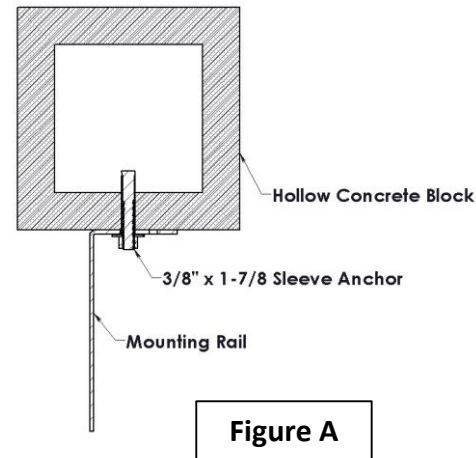

Approved Welding Methods

Fillet Welds Figure E.	Mounting Rail Bearing Brackets	1/8" fillet weld x 1-1/2" top and bottom then every 18" 3/16" fillet weld x 1-1/2" (4) places
Fillet Welds Figure E.	Mounting Rail Bearing Brackets	1/8" fillet weld x 1-1/2" top and bottom then every 18" 3/16" fillet weld x 1-1/2" (4) places

MxV™ Operating, Installation and Maintenance Guide

Common Parts

Manufacturer-Supplied Hardware & Fasteners

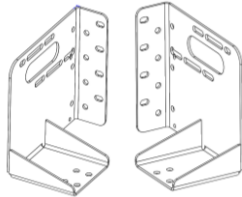

DR4789 & DR4790

Bearing Bracket (Left & Right)

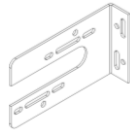

DR4582

Center Bracket

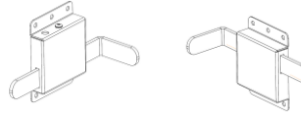

DR5350 & DR5351

Universal Lock Asm. (Left & Right)

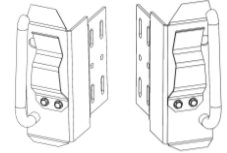

DR5165 & DR5166

Hold Down Bracket Asm. (Left & Right)

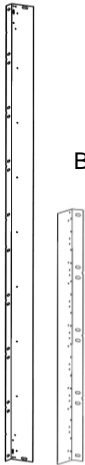

MOUNTING RAIL
(SEE BUILD SHEET)

DR4411 - 102" (Long)

DR4726 - 48" (Short)

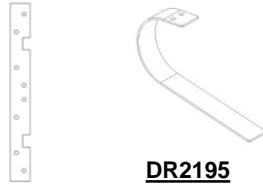

DR2195

Leaf Spring

DR4261

Junction Plate

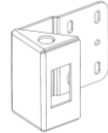

DR4695

Universal Lock Receiver



TEK® SCREWS

CP2189 - 1/4"-20 x1"

CP2108 - #10-16 X 3/4"



WASHERS

AT2012 3/8"

CP2061 1/2"



SHAFT KEY
(SEE BUILD SHEET)

DR2228 - 1/4" X 3/8"

DR2094 - 1/4" X 1/4"



HEX HEAD BOLTS

CP2104 - 3/8"-16x1-1/2"

CP2105 - 3/8"-16x1"



DR2082

3/8" x 3-3/4"
Shoulder Bolt



NYLOCK NUTS

CP2091 - 5/16"-18

CP2056 - 3/8"-16



CP2046

1/4"-20 Flange Nut



AT2018

1/4"-20 x 3/4"
Flange Bolt

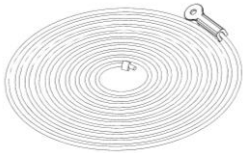

DOOR CABLES
(SEE BUILD SHEET)

DR5299/DR5300/DR5301



DR5028

Header Brush Asm.



DR2102

1" Bearing

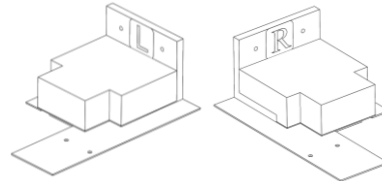

DR5431 & DR5432

Upper Track Seal (Left & Right)



DR2095

1" Split Shaft Collar

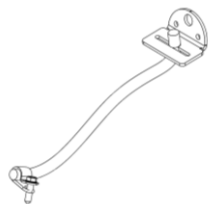

DR5353

Pulldown Rope Asm.

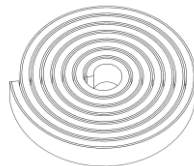

DR2340

Mounting Rail Foam
(or Silicone Caulk)



DR4696

Corrective Slot
Backer Plate



DR4770

Toe Plate



DR2087 (4")

Standard Lift Door
Drums (Left – black &
Right – red)

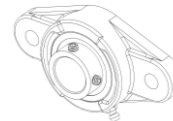

DR2115

2-Bolt Flange Bearing

SHAFT
(SEE BUILD SHEET)

DR2210 - 114", 126", 138"

DR2089 - 102, DR2090 - 114", DR2091 - 126"

□ Counterweight (CW) Parts

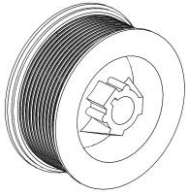

DR2187 (5-1/4")

Standard Lift CW Drums (Left – red & Right –black)

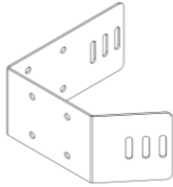

DR4709

6" CW Tube Bracket

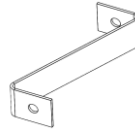

DR4896

Counterweight Z-Keeper

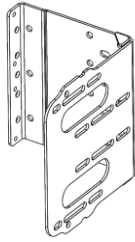

DR4797

Counterweight Bracket



CP2034

29" Tie Wrap



DR4955

Bearing Brkt Alignment plate

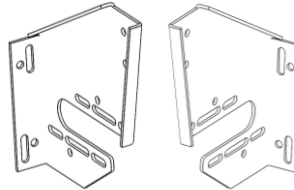

DR41038 & DR41083

Spring Support (Left & Right)

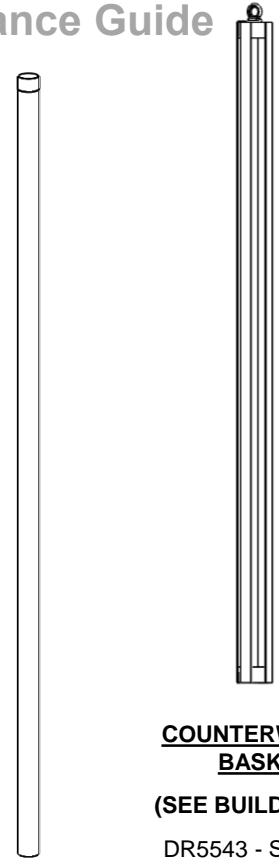

DR2186

Counterweight Tube

COUNTERWEIGHT BASKET

(SEE BUILD SHEET)

DR5543 - Small 41"

DR5544 - Medium 51"

DR5545 – Large 61"



DR5478

3/16" Counterweight Cable with DR2012 Quick Link

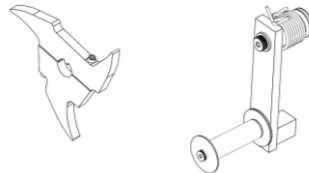

DR5540

Counterweight Safety Cable Kit

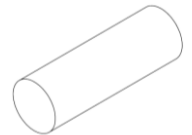

COUNTER WEIGHTS (SEE BUILD SHEET)

DR4901 - 12"

DR4902 - 6"

DR4903 - 3"

DR4904 - 2"

DR4905 - 1"

DR4906 - 1/2"

□ Torsion Spring Parts



DR2086

Vertical Lift Drums (Left - black & Right – red)



Torsion Spring (SEE BUILD SHEET)

(1L - red & 1R - black)



DR2194

14oz Multi Purpose Lube

Key Measurements

**IMPORTANT!!
ALL DIMENSIONS ARE FOR REFERENCE ONLY VERIFY NUMBERS
WITH INSTALLATION SHEET IN PARTS BOX!!!**

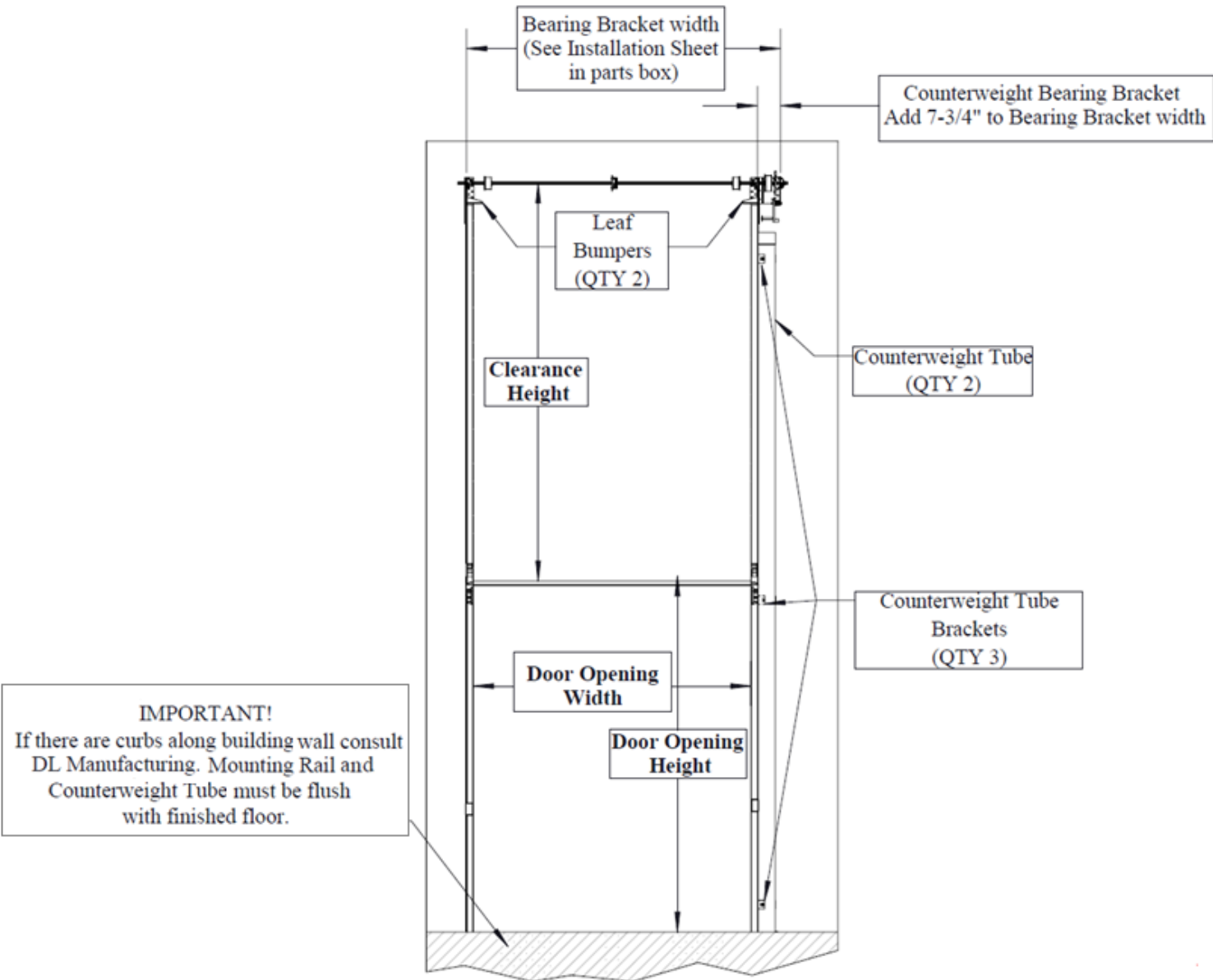

FIGURE #1. Key Measurements and Locations of Mounting Rails and End Bearing Assemblies.

Installing MxV Torsion Spring (TS) Doors

□ Attaching Mounting Rail and Track

NOTE:

The MxV door is built to customer specifications. Verify that measurements taken on the job site match those specified in the **As-Built** drawing provided with the door. If measurements DO NOT match those specified in the **As-Built** drawing please call our Service Department toll free for assistance (1-866-235-7468).

- Check parts list to verify that all required factory-supplied parts are present.
- Gather all required installer-supplied fasteners and hardware. (SEE PAGE 5-6)
- Verify the minimum clearance to the sides and above the door. (SEE FIGURE #1)

IMPORTANT!!!
Track support and alignment are critical!!!

The following conditions are required for the installation of the MxV door:

1. Door jamb is plumb and the header is level.
2. Adequate mounting surface available for Mounting Rails and End Bearing Assemblies.
3. Door jamb and walls must be inspected for decay, damage, crumbling etc. If a solid surface does not exist, the door jamb or wall must be repaired or rebuilt.
4. Use a plumb bob and level to ensure that each rail is level and square before fastening it to the door frame. In addition, if the door frame is not square, set rails so that they align with each other rather than with the door frame. (SEE FIGURE #2)

IMPORTANT!!!
DO NOT attach track to the Mounting Rail before welding!!!

NOTE:

Installers may determine that installation conditions that require welding mounting rails to the facility wall rather than using fasteners.

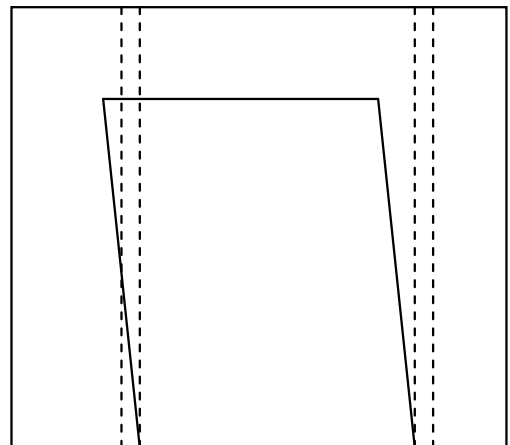

FIGURE #2. Proper track alignment when door frame is out of square (drawing not to scale).

❑ Attaching Mounting Rail and Track (Cont'd)

NOTE:

All Mounting Rails may be reversed.

- If door jamb or wall conditions restrict you from installing the Mounting Rails as indicated, rotate the rail 180° and attach them so that the short leg is facing away from the door opening and flush to the wall.
- Snap a new plumb line 2-1/4" to the outside of the initial line. The mounting rails **MUST** end up 4-1/2" plus door opening width "A" apart. (SEE FIGURE #3)

• Sealing Mounting Rail to Wall

1. Take Mounting Rail Foam strip and stick the side with adhesive against Mounting Rail or apply silicone caulk. Place foam on wall face of the Mounting Rail's short leg. The foam should be compressed between the Mounting Rail and wall when door is installed. (SEE FIGURE #4)
2. Ensure that foam does not totally cover the mounting holes in the short leg of the Mounting Rail. Foam to be inline with larger leg face.
3. The Mounting Rails below the door header need to be caulked to seal air and light leaks. Run a bead of caulk 3/8" or larger along the Lower Mounting Rails and the wall. If mounting to lumber it will also have to be caulked.
4. Fasten the Mounting Rails with either TEKS® #5 Screws, Sleeve Anchors or Wedge Anchors. Refer to **Approved Mounting Styles on Page #6**.

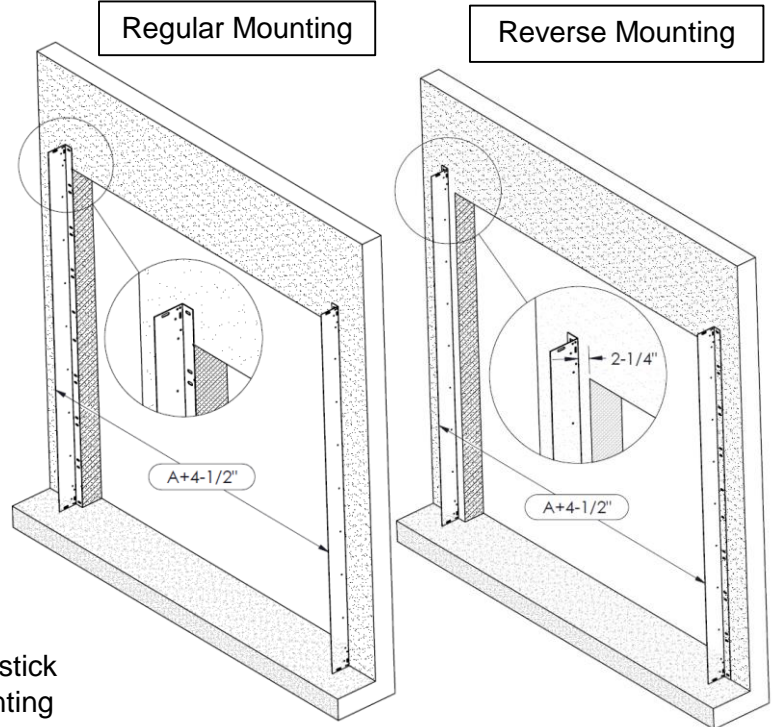

FIGURE #3. Regular & Reverse Mounting of Mounting Rails

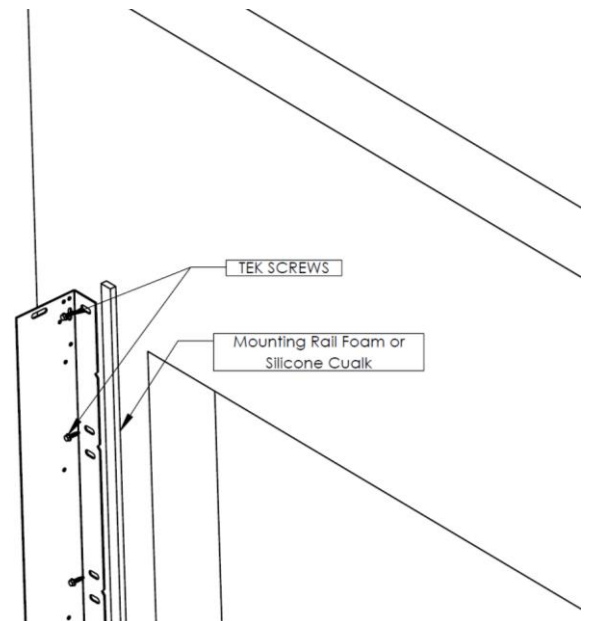

FIGURE #4. Attaching Mounting Rail Foam

□ Attaching Mounting Rail and Track (Cont'd)

• Attaching 48" Mounting Rail

NOTE:

Mounting Rails may be shimmed out from the door frame up to 1/2" to align them with each other. If the door frame is out of plumb by more than 1/2", contact factory before proceeding with install.

1. The Mounting Rail is comprised of two sections. For doors greater than 8ft high use additional shorter Mounting Rail section on the bottom and secure using the Junction Plates DR4261. **(SEE FIGURE #5 and Build Sheet)**
2. Align the shorter Mounting Rails with the door jamb so the distance apart matches the "A+4-1/2" dimension. If you cannot locate this measurement in the included paperwork, please call DL Manufacturing. **SEE FIGURE #3** if reverse mounting is required.
3. Attach Mounting Rails to wall using approved installer-supplied fasteners. Ensure Mounting Rails maintain the same spacing all the way to the top. Rails **MUST BE** kept level/plumb throughout. Mounting Rail spacing tolerance is ($\pm 1/4$ in). Re-measure spacing between Mounting Rails now.
4. Attach Mounting Rails using the provided AT2018 1/4"-20 x 3/4" bolts and CP2046 1/4"-20 Flange Nuts and secure using the DR4261 Junction Plates. Ensure Upper Mounting Rails maintain the same spacing all the way to the top. **(SEE FIGURE #6)**

IMPORTANT!!!

DO NOT attach Plastic Track to Mounting Rail until Mounting Rail is attached to wall!!!

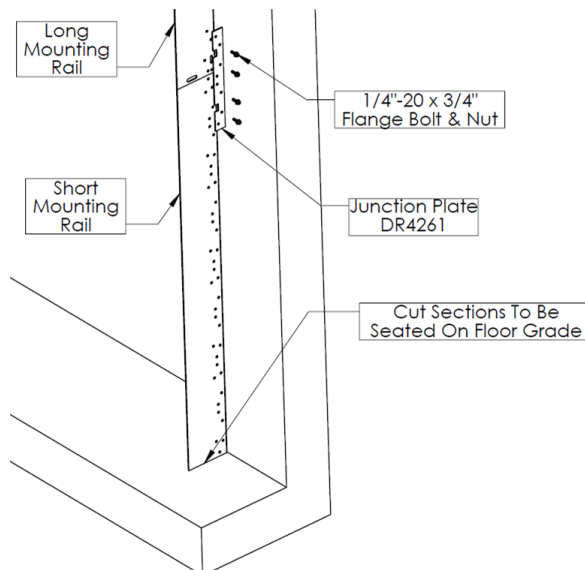

FIGURE #5.

Orientation of Long and Short Mounting Rails.

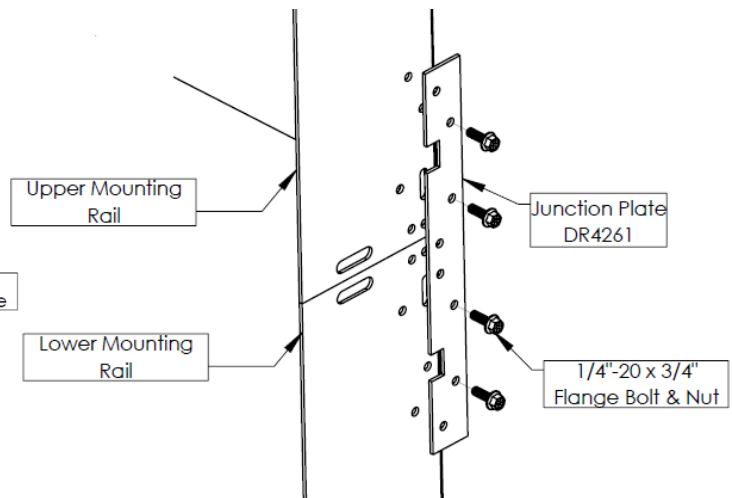

FIGURE #6.

Attaching Upper Mounting Rail to Lower Mounting Rail.

❑ Attaching Mounting Rail and Track (Cont'd)

• Mounting Plastic Tracks

NOTE:

Plastic Tracks are mounted over the Mounting Rails. Plastic Tracks are labeled to indicate position. **BL**=bottom left, **TL**=top left, **BR**=bottom right, **TR**=top right.

Attach the Lower Plastic Tracks onto the installed Mounting Rail on both sides of the door opening (BR + BL):

1. Slide the plastic track over the Mounting Rail so the webbed portion is pointing into the door opening.
2. Ensure that the plastic track is flush to the floor and fully seated over the Mounting Rail.
3. Using the pre-drilled holes in the Mounting Rail as guides, drill 1/4" holes through the plastic track. Apply heavy pressure to the plastic track while drilling the holes to ensure the plastic track will be fully seated.
4. Insert AT2018 1/4"-20 x 3/4" Flange Bolt through the holes so that the head is outside the track (touching the Mounting Rail) and the CP2046 1/4"-20 Flange Nuts are inside the track (touching the plastic track).
(SEE FIGURE #7)

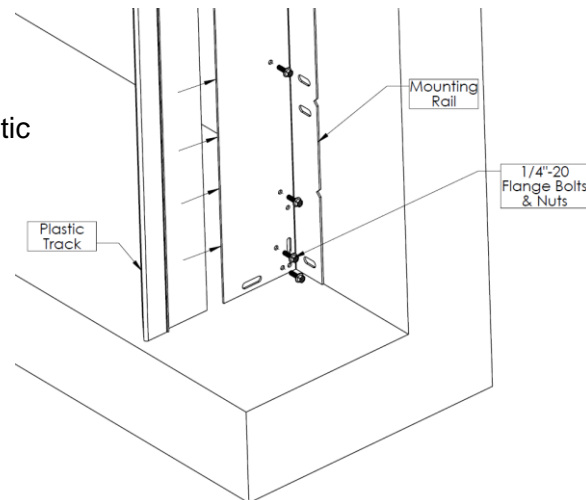

FIGURE #7. Attaching Lower Plastic Door Track.

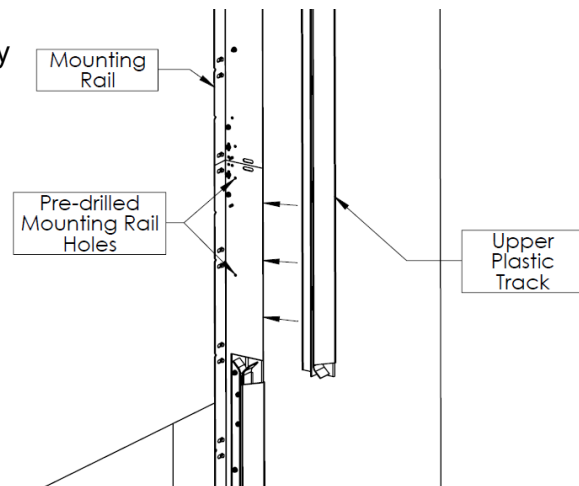

FIGURE #8. Attaching Upper Plastic Door Track.

Attaching the Upper Track to the Mounting Rail:

1. Slide the Upper Plastic Track over the Mounting Rail. Ensure the track is seated on the Mounting Rail and tight to the Lower Plastic Track.
2. Pre-drill holes in the Upper Plastic Track and secure with 1/4"-20 Flange Bolts and Nylock Nuts.
(SEE FIGURE #8)

Corrective Slot Backer Plates:

1. Attach the DR4696 Corrective Slot Backer Plates to Mounting Rail as shown in **FIGURE #9** using the provided CP2189 TEK® Screws. The Corrective Slot Backer Plates should be between the Plastic Track and the back of the Mounting Rail. The Corrective Slot Backer Plates support the plastic track corrective slot from the underside. Repeat for other side.

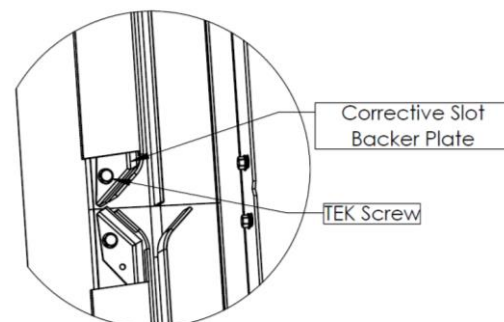

FIGURE #9.
Installing the Corrective Slot Backer Plates.

□ Mounting Bearing Brackets

IMPORTANT!!!

- For Counterweight Doors DR0800-SCW-6 thru DR0808-SCW-6 go to Page #18.

IMPORTANT: Ensure there is adequate structural support before proceeding with installation of Bearing Brackets.

1. Locate DR4789 (Left) & DR4790 (Right) Bearing Brackets to the height and width dimensions indicated on the **As-Built** drawing. Secure the Bearing Brackets to the wall using the appropriate fasteners listed on **PAGE #6**.
2. Use any combination of three slotted holes and one locking hole to mount the Bearing Brackets. **(SEE FIGURE #10)**

NOTE:

Upper Mounting Rails Should be flush with bottom of Bearing Brackets.

3. Attach the Bearing Brackets to the Upper Mounting Rails using the DR4261 Junction Plates, AT2018 1/4"-20 Flange Bolts and CP2046 Flange Nuts. **(SEE FIGURE #11)**
4. Level and plumb the Bearing Brackets, confirm they are the proper distance and height. **(See the As-Built drawing)**

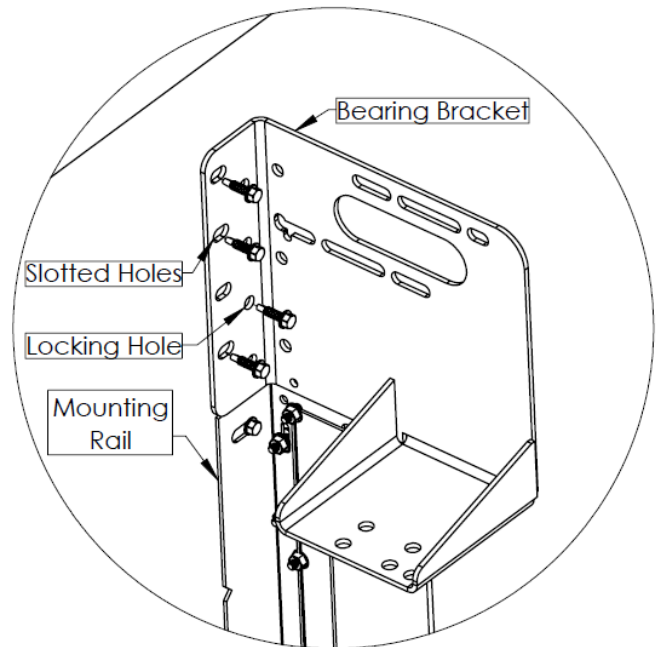

FIGURE #10. Bearing Bracket Installation for Torsion Spring.

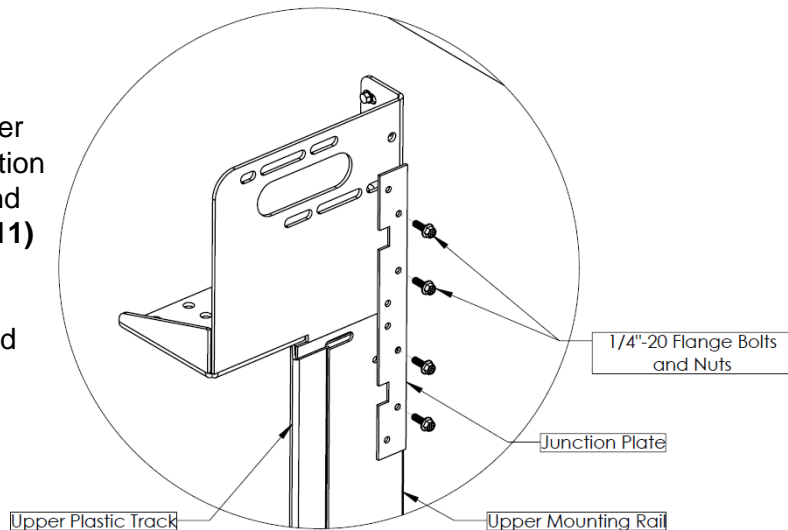

FIGURE #11. Attaching Bearing Brackets to Upper Mounting Rail.

□ Mounting Door Panels

**IMPORTANT!!!
PROTECT DOOR FROM ANY
WELDING OPERATIONS!!!**

1. Door panels are numbered to indicate the order of installation. Begin with Panel #1, which contains the bottom seal, then install Panel #2 second (handle), Panel #3 third, Panel # 4 fourth (handle with locks), etc. The panel which contains the header seal and the cable attachment will be installed last. **(SEE FIGURE #12)**
2. Attach Toe Plates DR4770 to Panel #1 on both left and right sides by removing lower sex bolts and washers. Reinstall washers, sex bolts and add CP2189 1/4"-20 x1" TEKS® screws. **(SEE FIGURE #13)**
3. Insert Panel #1 by feeding the Endcap brushes through the knockout slots into the track brush guide ensuring all bristles are captured. All hinges should be facing inward. **(SEE FIGURE #14)**
4. Lower Panel #1 to the floor. Ensure that the panel is properly seated flush with floor.
5. Remove washer and lower sex bolt on either side of Panel #2. Attach pull down rope and reinstall washer and sex bolt. Insert Panel #2 in the same fashion as Panel #1, lowering it to the top edge of the previously installed panel.

IMPORTANT: Be sure not to pinch bristles or the gap flap between panels and that the gap flap is seated in the brush guide of the track.

6. Insert supplied DR2082 3/8" x 3-3/4" Shoulder Bolt (located in Parts Box) through the hinge with the threads facing the track, and secure with supplied CP2091 5/16" Nylock Nut. Repeat on other side of door.

IMPORTANT: Hand tighten Nylocks at first to allow adjustability later on to plumb doors. When sections are all together tighten down all Nylocks.

**IMPORTANT!!!
REPEAT STEPS UNTIL ALL PANELS
ARE INSTALLED!!!**

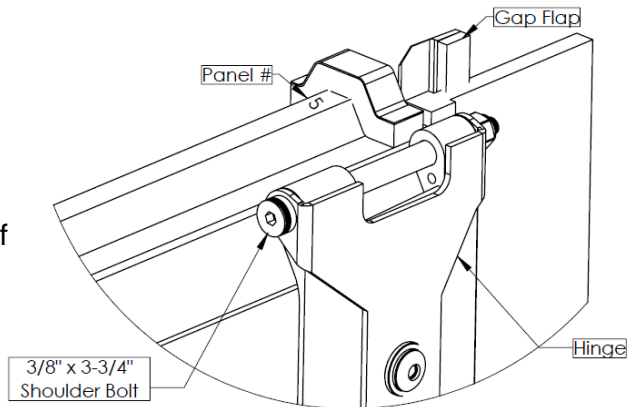

FIGURE #12. Door Panel numbering.

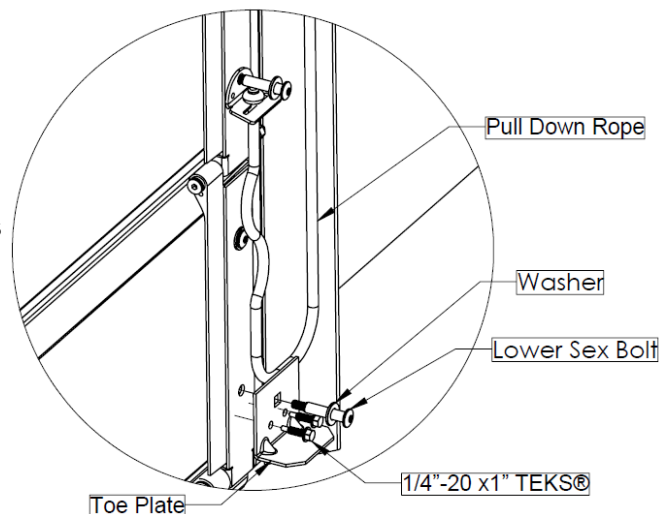

FIGURE #13. Attaching Pull Down Rope.

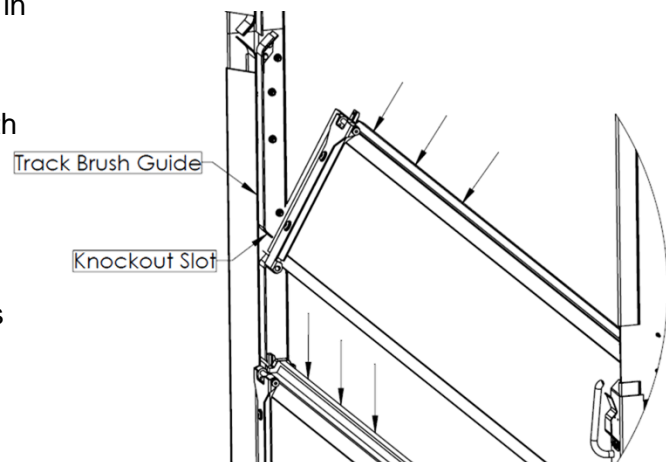

FIGURE #14. Endcap brushes through knockout slot

□ Mounting Torsion Springs, Shaft and Drums

IMPORTANT!!!

To avoid possible injury, pre-install shaft assembly with Torsion Springs on the ground!!!

1. Prepare the shaft assembly. Slide two DR2102 Spring Bearings onto the shaft followed by the Torsion Springs (**BLACK** on right, **RED** on left). (SEE FIGURE #15)

IMPORTANT!!!

Make sure the shaft passes through the center of the honeycomb structure and DR2102 Spring Bearings are supplied with the spring package!!!

NOTE: These bearings may or not be supplied with the Torsion Spring. If not, check part box for components. Apply DR2194 14oz Multi Purpose Lube to Torsion Springs.

2. Slide DR2086 Vertical Lift Drums onto both sides (**BLACK** on right, **RED** on left) followed by DR2115 Flange Bearing. Hand tighten set screws to avoid injury.
3. Secure the Flange Bearings with CP2104 3/8"-16 x 1-1/2" Hex Bolts, AT2012 3/8" Washers and CP2056 Nylocks, making sure the grease fittings are easily accessible. (SEE FIGURE #16)
4. Install entire shaft/spring assembly into the Bearing Brackets. The shaft must go through the holes farthest away from the wall.
5. Install the DR4582 Center Support Brackets using the appropriate fasteners listed on **PAGE #6**.
6. To install DR4582 Center Supports measure to center from DR4789 Bearing Bracket to DR4790 Bearing Bracket and space each Center Support a minimum of 3" from center.

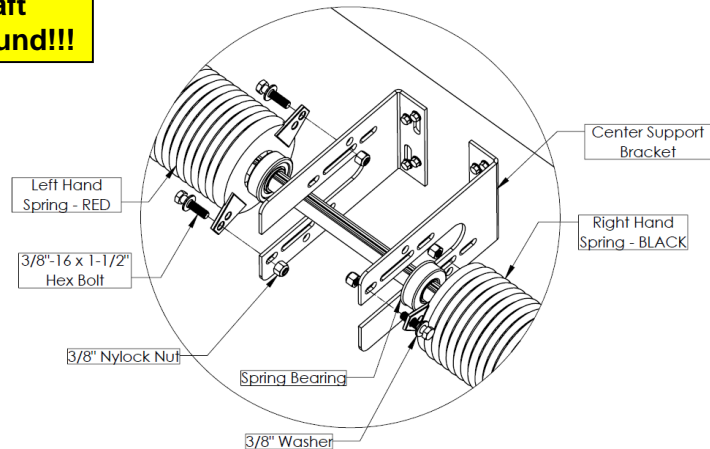

FIGURE #15. Spring Bearings and Spring ASM.

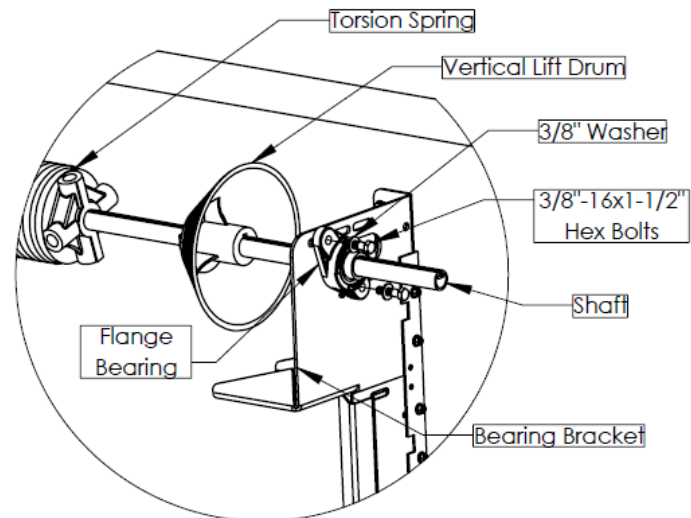

FIGURE #16. Shaft Assembly Into Bearing Brackets.

⚠ SAFETY NOTE

Verify the shaft is mounted straight and is not bowing. If so, the door will struggle to open/close.

□ Mounting Torsion Springs, Shaft and Drums Cont'd

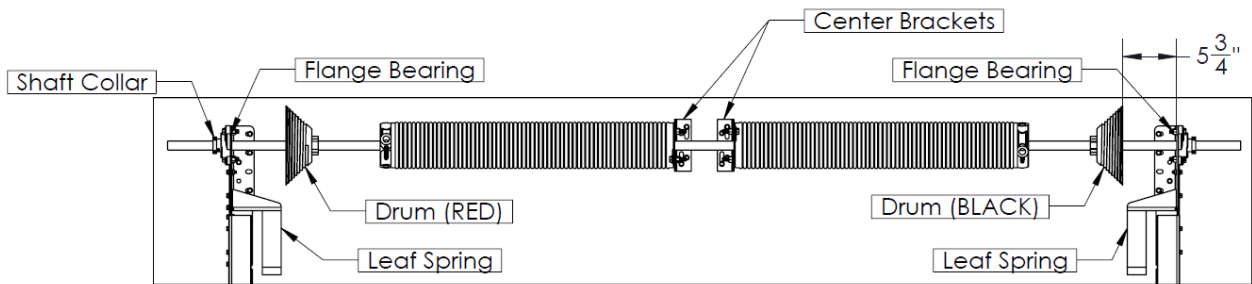

FIGURE #17. Torsion Spring Assembly.

Installing and positioning DR2095 Shaft Collars, DR2086 Vertical Lift Drums and Cable:

1. Using 1/8" Hex Driver, tighten the set screws in Flange Bearings so the shaft does not slide from side to side.
2. Slide Split Shaft Collars over the ends of shaft on each side tight to the DR2115 Flange Bearings and tighten set screws with 3/16" Hex Driver.
3. Align the drums so the cable does not rub (**Approx. 5-3/4" from the bearing bracket**). Install the DR2094 Shaft Keys and tighten both drum set screws on each side.
4. Attach cable to the lift bracket on the top panel. (**SEE FIGURE #18**)
5. Attach the cables to the drums and wrap around Vertical Lift Drums until the cables are taut. These cables should be wound so that the cables come off the back of the drum.
6. Clamp a vise grip around shaft and wedge it against the wall so the shaft can no longer turn freely. (*Ensure the vise grip is very secure*).

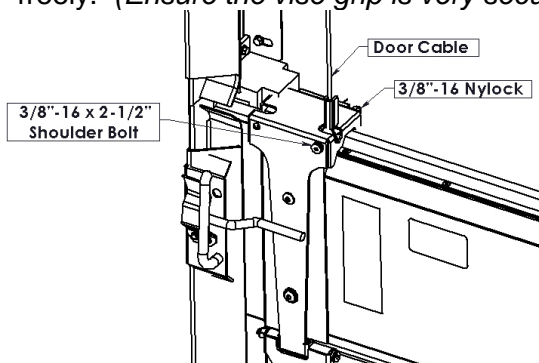

FIGURE #19. Door Cable Attachment.

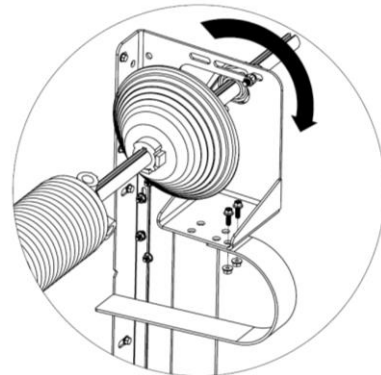

FIGURE #20. Leaf Spring Assembly

Installing Leaf Springs and Winding Torsion Springs:

1. Install the DR2195 Leaf Spring using two CP2105 3/8"-16x1" Hex Bolts and CP2056 Nylock Nuts in the outer most holes. (**SEE FIGURE #20**)
2. Wind torsion springs according to the number of turns suggested on the MxV Packing Checklist. This number is just a starting point and tension may need to be added or removed accordingly. The MxV door should be slightly upward biased when finished.

□ Installing Hold Down Bracket Asm. & Door Locks

• Spring Plate

1. Attach DR5165 (Left) & DR5166 (Right) Hold Down Bracket Assembly to Mounting Rail on each side, using the provided CP2189 TEK® Screws. Adjust to align with Hold Down Bar. Verify that the TEK® Screws go through the Plastic Track and not just push it away from the Mounting Rail. (SEE FIGURE #21)

NOTE:

The Spring Clip is adjustable. There are three extra sets of pre-tapped holes in the bracket behind the clip. When the door is in the down position, the Hold Down Bar should be positioned towards the top-center of the clip.

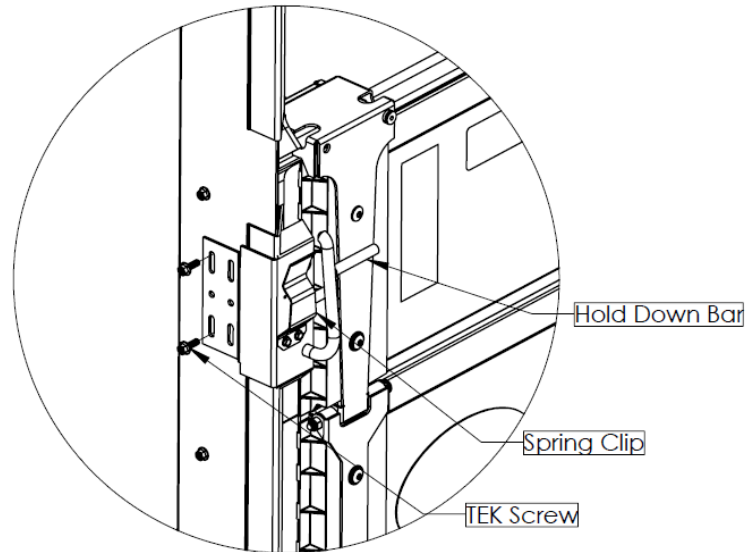

FIGURE #21.

Installing the Hold Down Bracket Assembly.

• Door Locks and Receivers

1. Attach the DR5350 (Left) & DR5351 (Right) Door Slide Locks to the metal End Cap braces (1-LH, 1-RH) on **Panel #4** using at least two CP2189 Tek Screws on each Door Slide Lock.
2. Engage the slide bar of the Door Slide Locks and position the DR4695 Universal Lock Receivers so the top of the slot in the Universal Lock Receiver is bottomed out on the top of the Door Slide Lock.
3. Once positioned properly, fasten the Universal Lock Receivers to the Plastic Track and Mounting Rail using at least two CP2189 TEK® Screws per Universal Lock Receiver. (SEE FIGURE # 22)

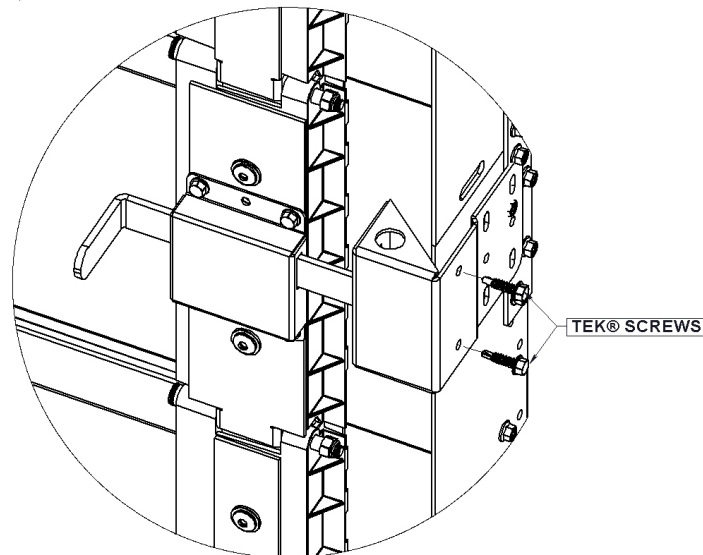

FIGURE #22. Attaching Locks and Receivers (Right Side shown).

□ Installing Header Seal Brush & Upper Track Seals

NOTE:

The Wall Header Brush Seal Assembly must maintain contact with the top panel seal in the closed or locked position. This creates the seal at the top of the door.

1. Crimp ends of the Wall Header Brush Seal Assembly to ensure brush does not come out.
2. Attach Header Brush Seal Assembly to header using Tapcon Concrete Screws. When the door is closed the wall header brush should be touching the underside of the door header seal. **(SEE FIGURE #23)**

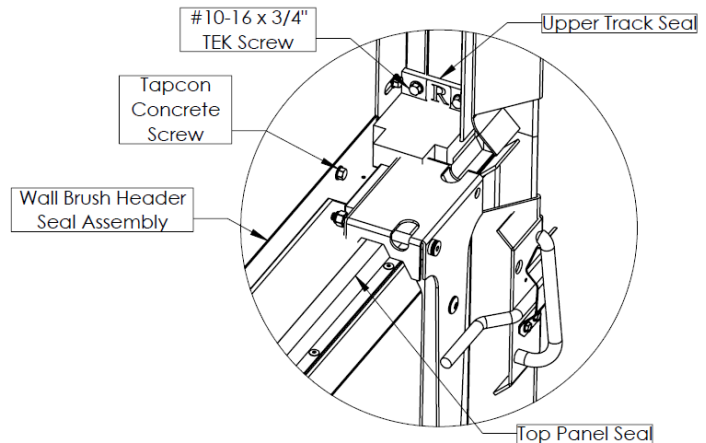

FIGURE #23.

Installing Header Seal Brush Assembly.

NOTE:

To make the installation of the Upper Track Seal easier, raise the door all the way and pull the bottom two panels out of the track towards the inside of the building. This will allow you better access to the area where the Upper Track will attach.

1. Starting on the left side of the door, locate the Upper Left Track Seal DR5431 as shown in **(FIGURE #24)**. Fasten the seal to the Mounting Rail using the supplied CP2108 #10-16 x 3/4" TEK® Screws.
2. Verify that all gaps are sealed between the door, Header Brush and wall when the door is in the closed position.
3. Repeat on other side using DR5432 (Right) Upper Track Seal.

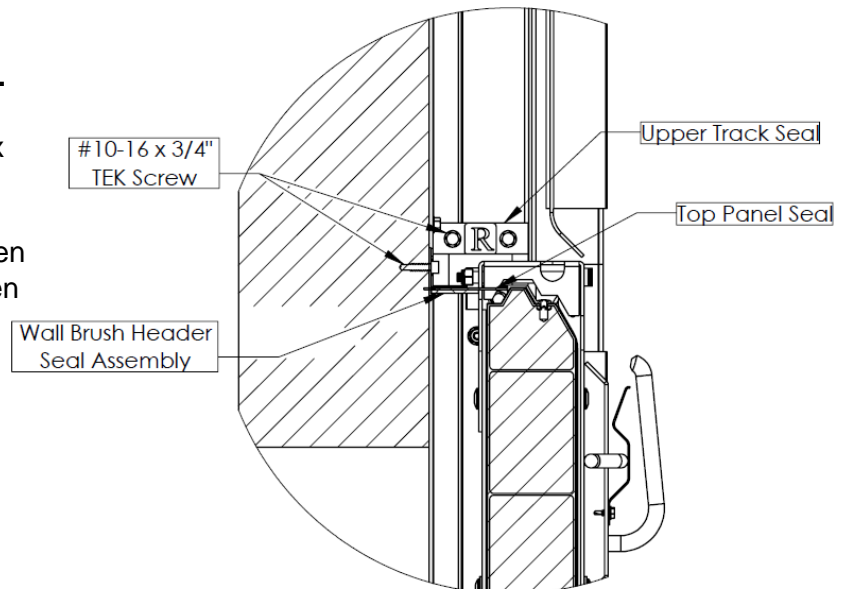

FIGURE #24.

Installing Upper Track Seal.

Installing MxV Counterweight (CW) Doors

□ Mounting Counterweight Bearing Brackets

IMPORTANT: Ensure there is adequate structural support before proceeding with installation of Bearing Brackets.

1. Locate DR4789 (Left) & DR4790 (Right) Bearing Brackets to the height and width dimensions indicated on the **As-Built** drawing. Secure the Bearing Brackets to the wall using the appropriate fasteners listed on **PAGE #6. (SEE FIGURE #25)**

NOTE:

Determine which side of the door the counterweight stack will be located. When counterweight location has been determined, build counterweight bearing bracket assembly on the floor before mounting.

2. Attach the DR4797 Counterweight Bearing Bracket using CP2105 3/8"-16x1" Bolts, CP2056 3/8"-16 Nylock Nuts and DR4955 Bearing Bracket Alignment Plate to the appropriate Bearing Bracket (Left or Right). **(SEE FIGURE #26)**

3. Attach the Bearing Brackets to the Upper Mounting Rail using the Counterweight Bearing Alignment Plate, AT2018 1/4"-20 Flange Bolts, CP2046 Flange Nuts.

4. Level and plumb **BOTH** the Bearing Brackets and Counterweight Bearing Bracket, confirm they are the proper distance and height. **(See As-Built drawing)**

5. Use any combination of three slotted holes and one locking hole to mount the Bearing Brackets and Counterweight Bearing Bracket. **(SEE FIGURE #27)**

6. Doublecheck Bearing Brackets are plumb and level.

NOTE: Side opposite of counterweight stack will be installed without counterweight bracket.

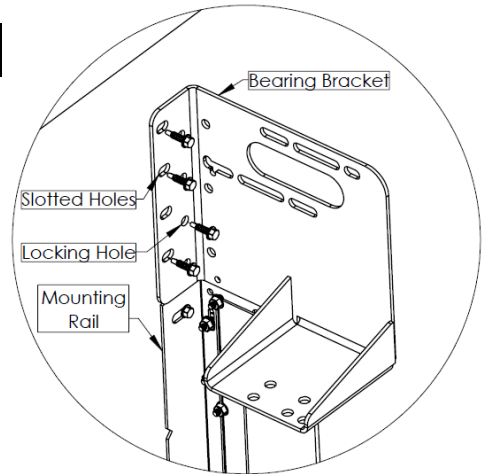

FIGURE #25. Bearing Bracket Installation

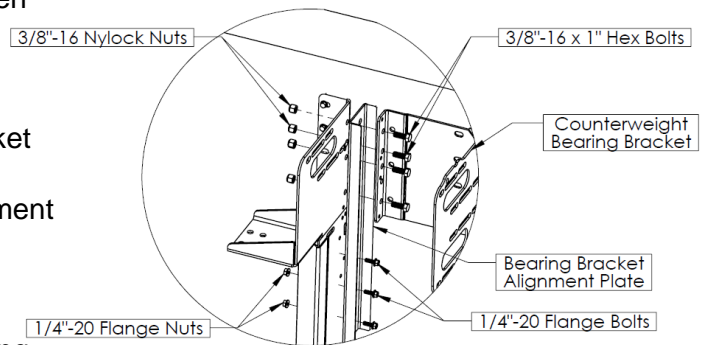

FIGURE #26. Attaching Bearing Brackets & Counterweight Bearing Brackets

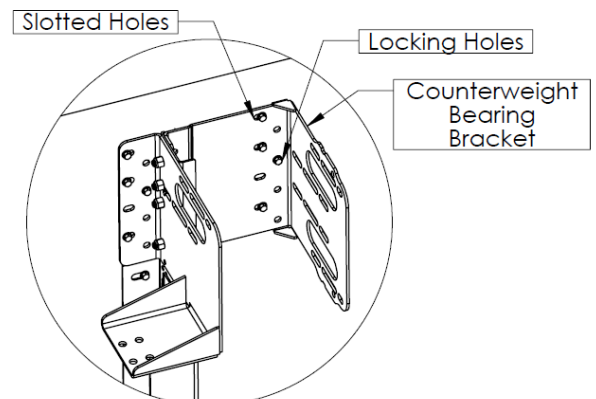

FIGURE #27. Counterweight Bracket Installation

□ Mounting Counterweight Shaft Assembly & Drums

Preparing the Shaft Assembly:

1. Slide DR2087 Door Drum (**BLACK** on the left, with cable coming off the front), DR2115 Flange Bearing for the DR4582 Center Support and Door Drum (**RED** on the right, with the cable coming off the front) onto the shaft in the order above. Add a second Flange Bearing to the shaft assembly on the counterweight side. (**SEE FIGURE #28**)
2. Bring the assembly up to the Bearing Bracket Assembly and insert one end of the shaft into one Bearing Bracket Assembly and then the other end into the other Bearing Bracket Assembly.
3. Slide the shaft slightly to either the left or right (**Depending on counterweight stack location**). Install DR2187 Counterweight Drum (**BLACK** on right, **RED** on left) with the cable coming off back side between the Bearing Bracket and Counterweight Bearing Bracket.
4. Attach the Flange Bearings to the Bearing Bracket and Counterweight Bearing Bracket using CP2104 3/8"-16x1-1/2" bolts and CP2056 3/8"-16 Nylock Nuts.
5. Door Drums should be positioned **5-3/4"** from the Bearing Bracket and cables come off the front of the Door Drums. (**SEE FIGURE #29**)
6. The Counterweight Drum should be positioned **1-3/4"** from the Bearing Bracket and the cable comes off the back of the Counterweight Drum. Install the DR2228 Shaft Key and tighten the set screws. Do the opposite if mounting on left hand side. (**SEE FIGURE #30**)
7. The DR4582 Center Support is located between the DR4789 (Left) & DR4790 (Right) Bearing Brackets.

NOTE:

If installing an operator, be sure to bias the shaft to the side of the door on which the operator will be positioned.

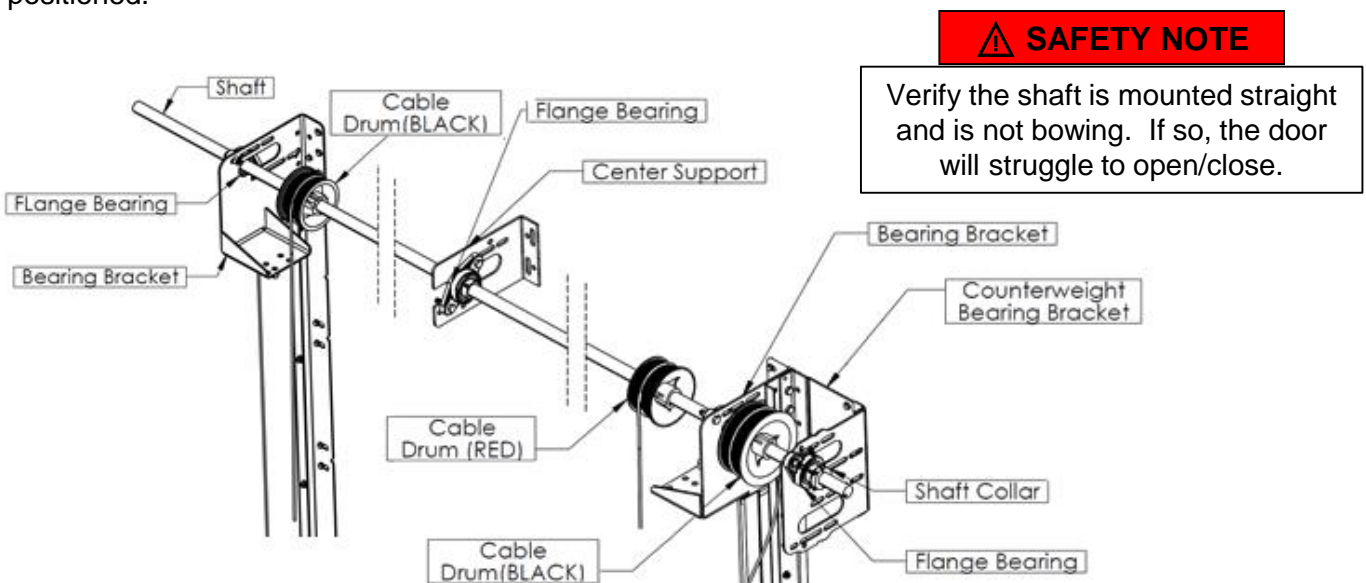

FIGURE #28. Right Hand Mounting

□ Mounting Counterweight Shaft Assembly & Drums Cont'd

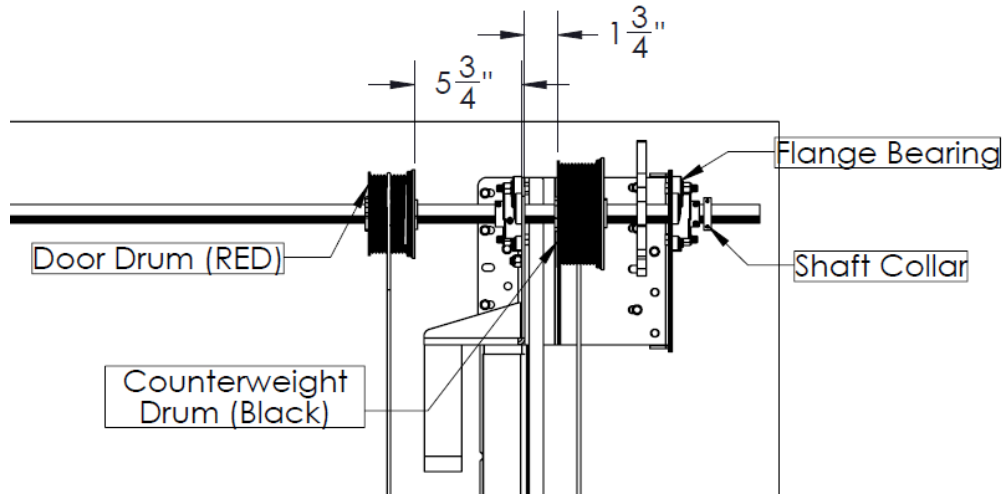

FIGURE #29. Positioning Door Drums

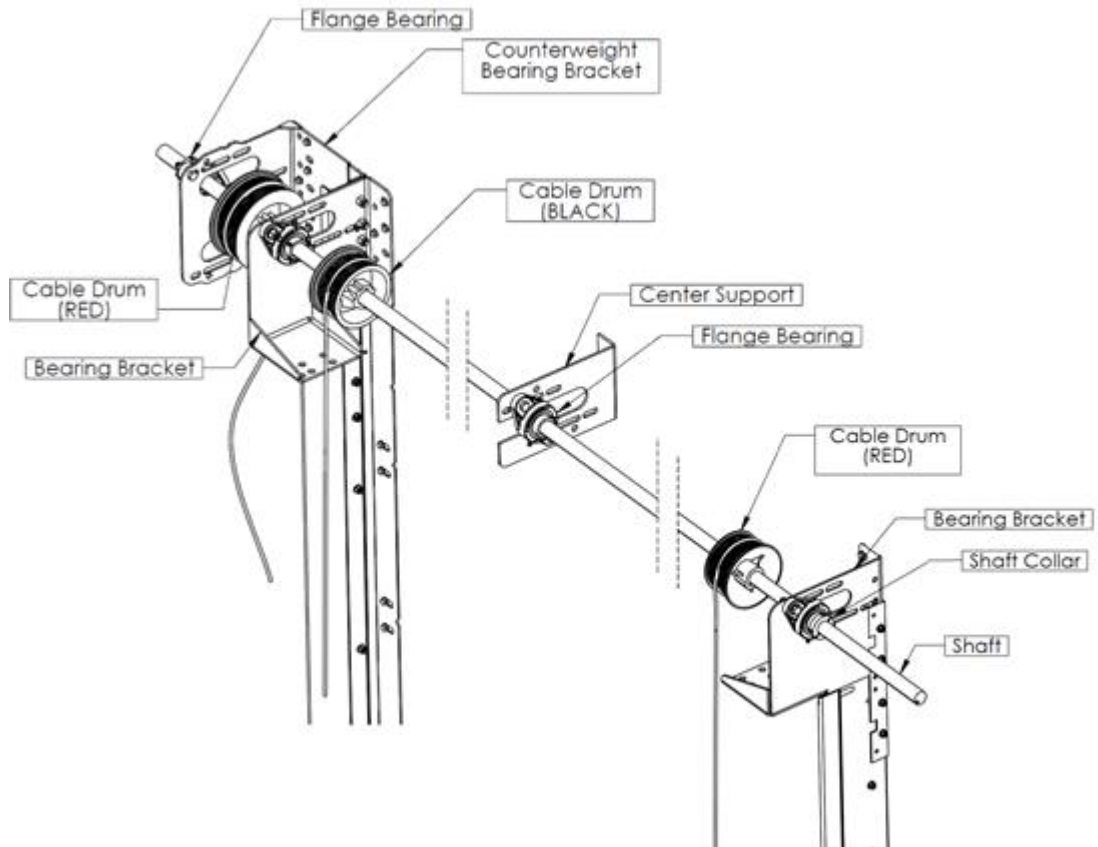

FIGURE #30. Left Hand Mounting

□ Mounting Door Panels

**IMPORTANT!!!
PROTECT DOOR FROM ANY
WELDING OPERATIONS!!!**

1. Door panels are numbered to indicate the order of installation. Begin with Panel #1, which contains the bottom seal, then install Panel #2 second (handle), Panel #3 third, Panel # 4 fourth (handle with locks), etc. The panel which contains the header seal and the cable attachment will be installed last. **(SEE FIGURE #31)**
2. Attach Toe Plates DR4770 to Panel #1 on both left and right sides by removing lower sex bolts and washers. Reinstall washers, sex bolts and add CP2189 1/4"-20 x1" TEKS® screws. **(SEE FIGURE #32)**
3. Insert Panel #1 by feeding the Endcap brushes through the knockout slots into the track brush guide ensuring all bristles are captured. All hinges should be facing inward. **(SEE FIGURE #33)**
4. Lower Panel #1 to the floor. Ensure that the panel is properly seated flush with floor.
5. Remove washer and lower sex bolt on either side of Panel #2. Attach pull down rope and reinstall washer and sex bolt. Insert Panel #2 in the same fashion as Panel #1, lowering it to the top edge of the previously installed panel.

IMPORTANT: Be sure not to pinch bristles or the gap flap between panels and that the gap flap is seated in the brush guide of the track.

6. Insert supplied DR2082 3/8" x 3-3/4" Shoulder Bolt (located in Parts Box) through the hinge with the threads facing the track, and secure with supplied CP2091 5/16" Nylock Nut. Repeat on other side of door.

IMPORTANT: Hand tighten Nylocks at first to allow adjustability later on to plumb doors. When sections are all together tighten down all Nylocks.

**IMPORTANT!!!
REPEAT STEPS UNTIL ALL PANELS
ARE INSTALLED!!!**

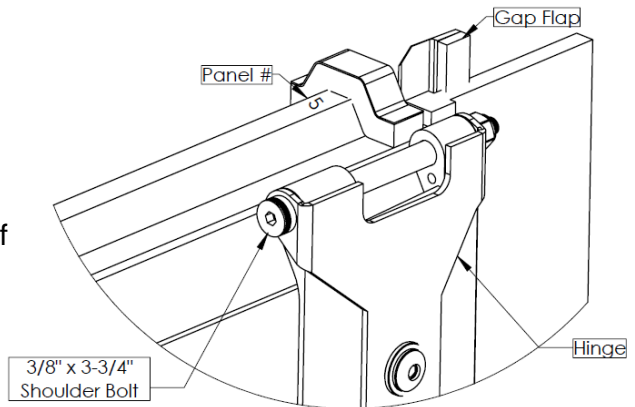

FIGURE #31. Door Panel numbering.

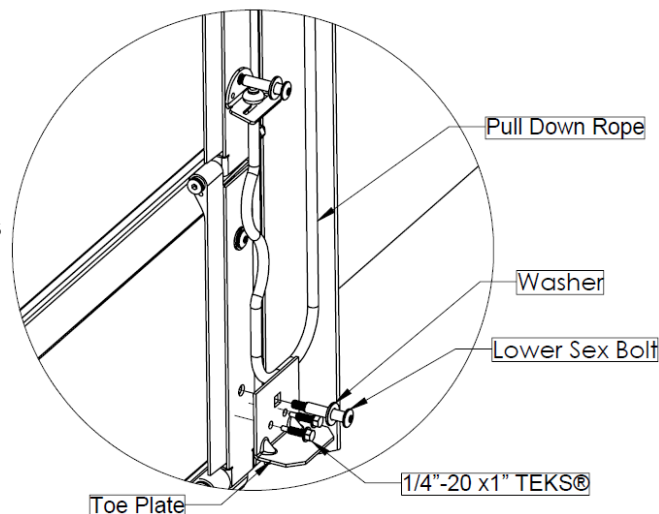

FIGURE #32. Attaching Pull Down Rope.

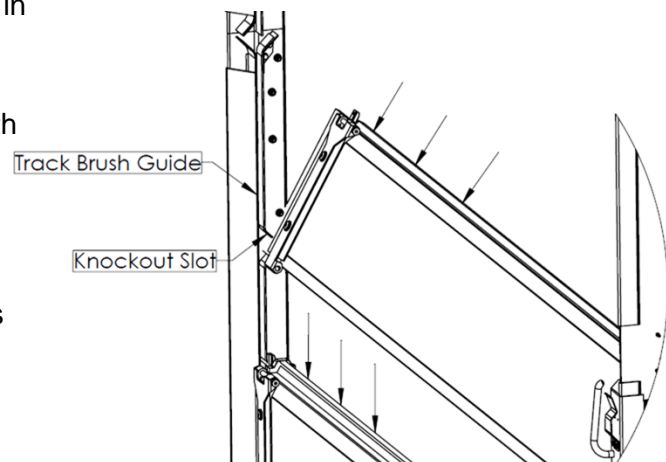

FIGURE #33. Endcap brushes through knockout slot

□ Mounting Safety Cog

1. Attach the Door Cables to the lift brackets on the top panel of the MxV door. (SEE FIGURE #34)
2. Ensure the DR2187 Counterweight Drum is 1-3/4" from the Bearing Bracket.
3. Remove the Safety Cog from DR5540 Counterweight Safety Cable Kit and separate halves by removing the socket head cap screws.
4. Align the Safety Cog halves on the shaft between the Counterweight Drum and DR4797 Counterweight Bearing Bracket. (SEE FIGURE #35).
5. Verify that the key tab on one half of the Safety Cog aligns with the shaft keyway and orientation of the Safety Cog matches. The tines should be pointing toward the floor. (SEE FIGURE #36A or #36B).
6. **IMPORTANT:** Verify that the Safety Cog outside face is 1-1/8" from the Counterweight Bearing Bracket SEE FIGURE #45. The DR5540 Counterweight Cable Safety Kit is designed to stop the MxV door falling in the event of a counterweight cable failure. If assistance is needed, call DL Manufacturing Service Department toll free at (1-866-235-7468).
7. Using 1/8" Hex Driver, tighten the set screws on DR2115 Flange Bearings so the shaft doesn't slide from side to side.
8. Slide the DR2095 Split Shaft Collar over the ends of shaft on each side tight to the Flange Bearing.

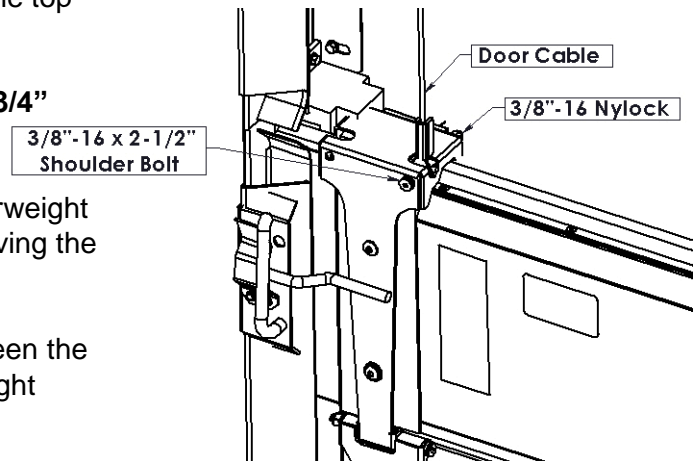

FIGURE #34. Door Cable Attachment

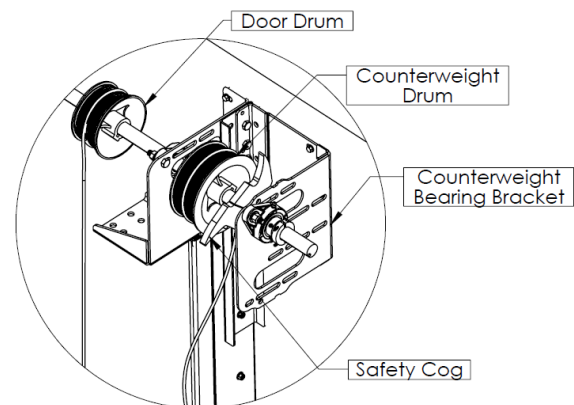

FIGURE #35. Safety Cog Alignment

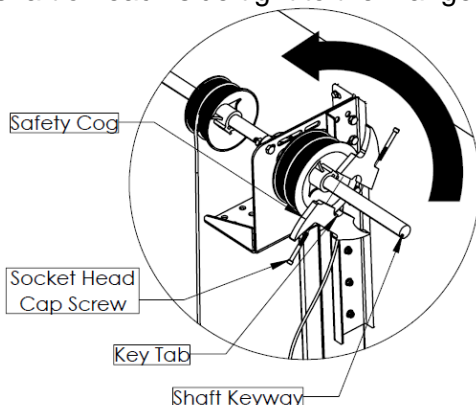

FIGURE #36A. Right Hand Safety Cog Mounting

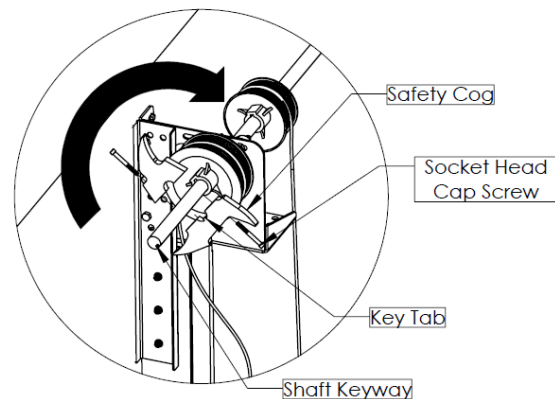

FIGURE #36B. Left Hand Safety Cog Mounting

□ Attaching Cables, Leaf Springs and Counterweight Tube Brackets

1. Attach the counterweight cable to the Counterweight Drum. Cables should be coming off the back of the drum. Rotate the drum, wrapping the cables around the drum until there is approximately **6"-8"** of cable hanging off the drum.
2. Insert the ends of the Door Cables through the top slots on the side of the Door Drums and wrap cables around drums until the cable is taut. Cables should be coming off the front side of the drum, away from the wall. Clamp a vise grip around shaft and wedge it against the wall so the shaft can no longer turn freely (**Ensure the vise grip is very secure**). **SEE FIGURE #37**

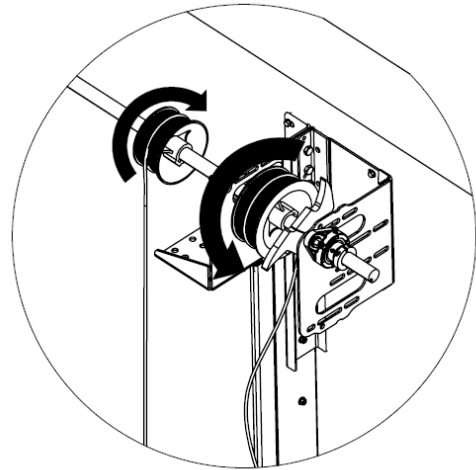

FIGURE #37. Attaching Cables

3. Install the DR2195 Leaf Spring using two CP2105 3/8"-16x1" Hex Bolts and CP2056 Nylock Nuts in the outer most holes. (**SEE FIGURE #38**)

NOTE:

Some doors include DR41038 (Left) or DR41083 (Right) Center Support Brackets for additional Leaf Springs. **DR4582 Center Support Bracket will be replaced if these are used.**

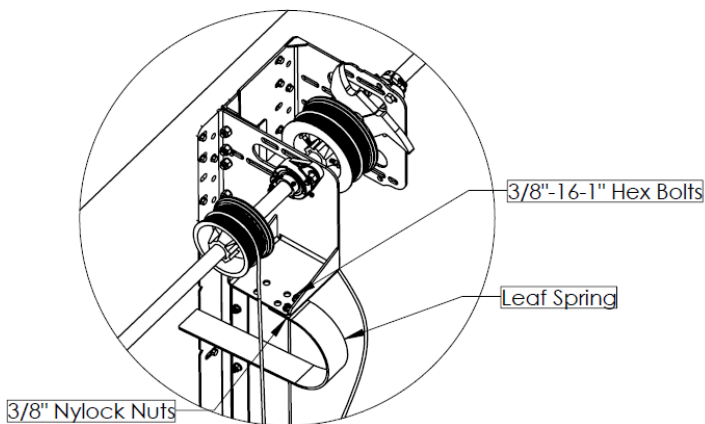

FIGURE #38. Installing Leaf Springs

4. Attach the DR4709 Counterweight Tube Brackets to the Mounting Rails using the supplied CP2189 TEK® screws. (**SEE FIGURE #39**)
5. There are three Counterweight Tube Brackets, place one bracket near the floor, one towards the top and the other equal distant between the two.

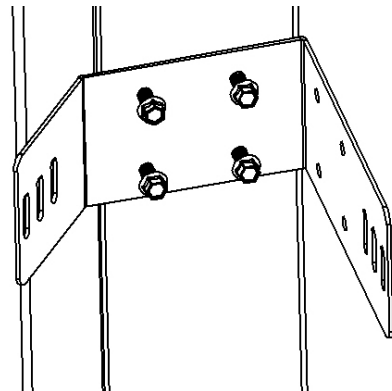

FIGURE #39. Attaching Counterweight Tube Brackets.

□ Counterweight Stack Installation

1. Verify there are no curbs along the building wall that will interfere with the counterweight path.
2. **Ensure the door is locked before attaching counterweights. If MxV Vertical Lift Door does not have the lock option, adequately secure MxV door by tying off the pull down strap to ensure door does not fly up when counterweights are attached.**
3. Place Counterweight Basket upright and connect to the DR2012 Quick Link on the end of the cable (make sure the cable is hanging off the back of the Counterweight Drum).
4. Remove the 3/8" Bolt and Nylock Nut from the vertical strap to gain access to the interior of the basket.
5. Install the Counterweights per the **Build Sheet** stacking configuration with the weights largest to smallest.
6. Re-attach the vertical strap using the hardware removed in **Step #3**.
7. Test operation of MxV door. A properly balanced door should be slightly upward biased, the door will always clear the header but will **NOT** bounce back into the opening.
8. Add or remove smaller counterweight shims as necessary to properly balance the MxV door.
9. Install the DR4896 Counterweight Z-Keeper, making sure it is tight against the counterweight stack.
9. Using two CP2189 TEK® Screws, secure the keeper to the two vertical straps so the counterweights are protected.
(SEE FIGURE #40)

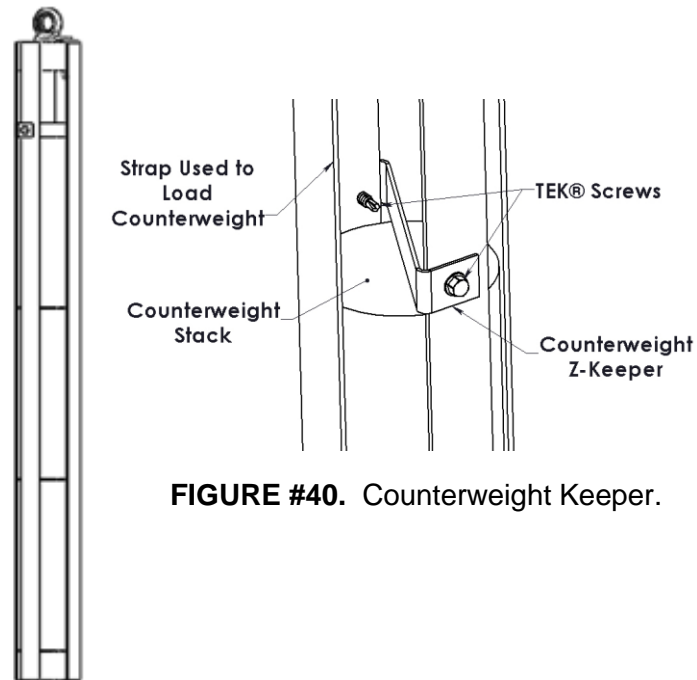

FIGURE #40. Counterweight Keeper.

Counterweight Reference Chart

DL Mfg Part #	Weight	Length
DR4901	42.7lbs	12"
DR4902	21.3lbs	6"
DR4903	10.6lbs	3"
DR4904	7.1lbs	2"
DR4905	3.5lbs	1"
DR4906	1.7lbs	1/2"

⚠ CAUTION

Counterweights are very heavy; please use extreme caution and proper lifting techniques when handling to avoid injury. Only qualified installation professionals should handle counterweights.

□ Mounting Counterweight Tubes

NOTE:

Do not attach the DR4896 Counterweight Z-Keeper to the strap used to load the counterweights. Use straps on either side of the removable member.

1. Once the Counterweight Z-Keeper is installed, wrap the Counterweight Basket with CP2034 Zip Ties to prevent any clanging (**the first at 1/3 from bottom, the second at 2/3 from bottom**). The Zip Ties should never be used to hold or secure counterweights. Cut the Zip Ties close to the Counterweight Basket.
2. Fit one **LONG** and one **SHORT** DR2186 Counterweight Tube tightly together and slide them over the counterweights, with the longer tube on the bottom, until the tubes are flush to the Mounting Rail. Be sure to seat the tubes all the way, otherwise they may pull apart resulting in damage.
3. Utilizing the slots on the DR4709 Counterweight Tube Brackets, attach the Counterweight Tubes to the Counterweight Tube Brackets with the provided CP2034 Tie Wrap. (**SEE FIGURE #41**)
4. Verify all steps have been completed before attaching cables and/or mounting the Swing Arm from DR5540 Counterweight Safety Cable Kit. (**SEE FIGURE #42**)

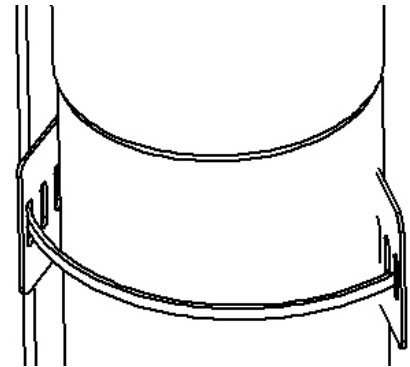

FIGURE #41. Attaching Counterweight Tubes.

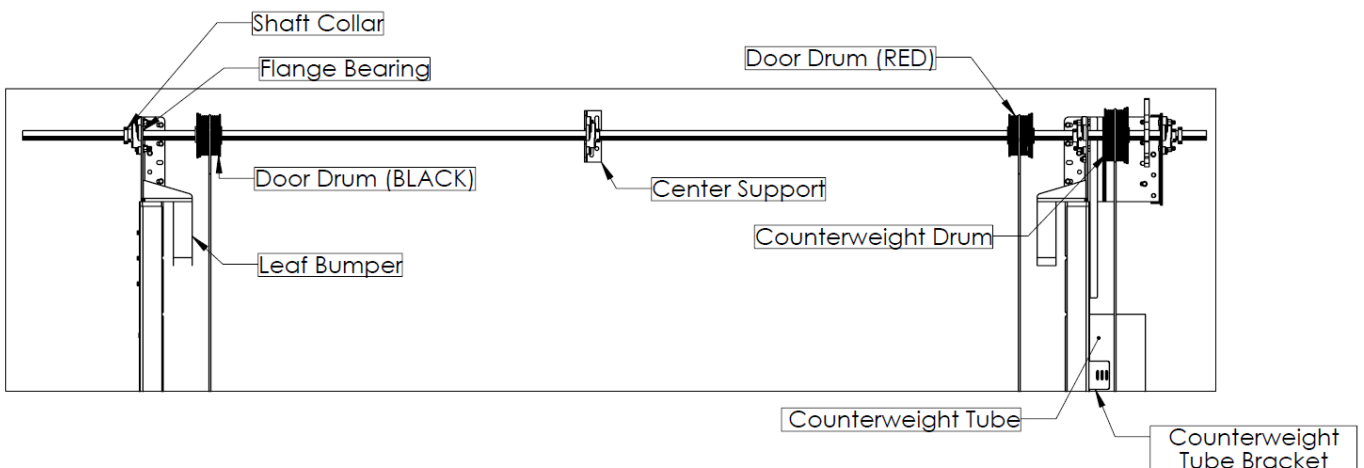

FIGURE #42. Counterweight Shaft Assembly

□ Mounting Swing Arm Assembly

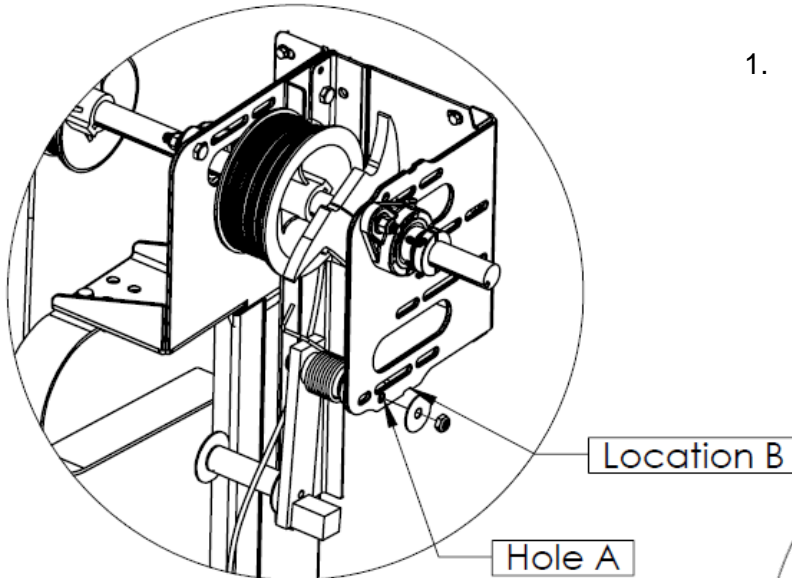

FIGURE #43.

2. Move the counterweight cable out of the way and rotate the Swing Arm Assembly to ensure the Swing Arm Assembly rotates freely without binding and will engage the Safety Cog. The striker block is positioned On the Swing Arm Assembly to engage the Safety Cog in the event of a counterweight cable failure. (SEE FIGURE #44)

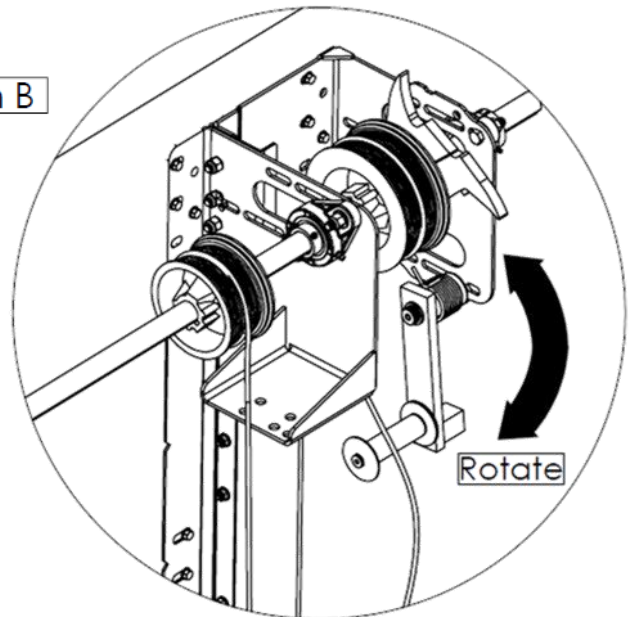

FIGURE #44.

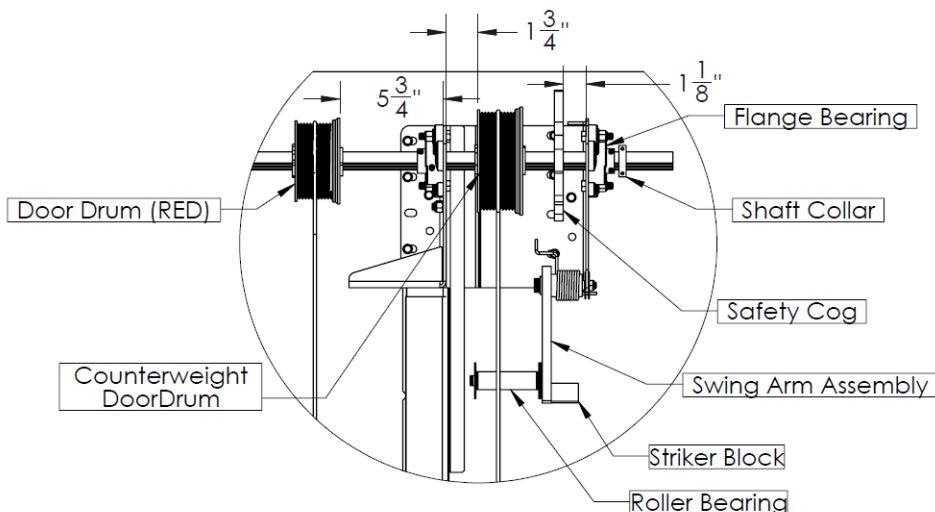

FIGURE #45.

3. Position the cable in front of the Swing Arm Assembly Roller Bearing. (SEE FIGURE #45)

□ Installing Hold Down Bracket Asm. & Door Locks

• Spring Plate

1. Attach DR5165 (Left) & DR5166 (Right) Hold Down Bracket Assembly to Mounting Rail on each side, using the provided CP2189 TEK® Screws. Adjust to align with Hold Down Bar. Verify that the TEK® Screws go through the Plastic Track and not just push it away from the Mounting Rail. (SEE FIGURE #46)

NOTE:

The Spring Clip is adjustable. There are three extra sets of pre-tapped holes in the bracket behind the clip. When the door is in the down position, the Hold Down Bar should be positioned towards the top-center of the clip.

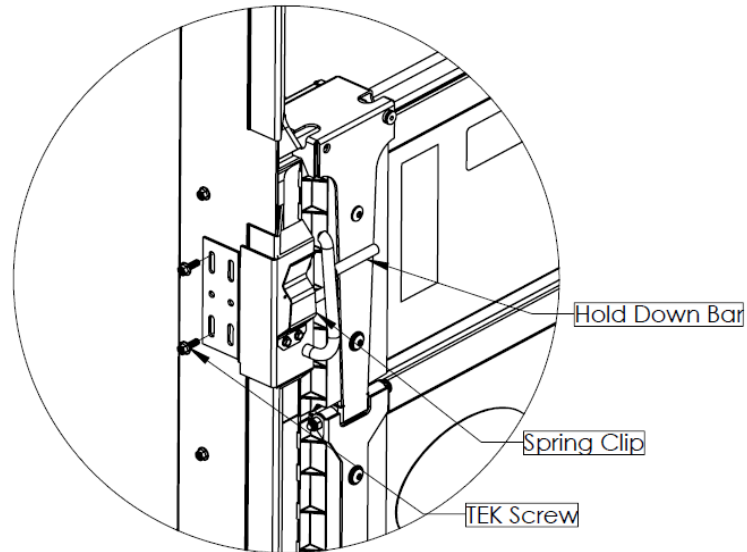

FIGURE #46.

Installing the Hold Down Bracket Assembly.

• Door Locks and Receivers

1. Attach the DR5350 (Left) & DR5351 (Right) Door Slide Locks to the metal End Cap braces (1-LH, 1-RH) on **Panel #4** using at least two CP2189 Tek Screws on each Door Slide Lock.
2. Engage the slide bar of the Door Slide Locks and position the DR4695 Universal Lock Receivers so the top of the slot in the Universal Lock Receiver is bottomed out on the top of the Door Slide Lock.
3. Once positioned properly, fasten the Universal Lock Receivers to the Plastic Track and Mounting Rail using at least two CP2189 TEK® Screws per Universal Lock Receiver. (SEE FIGURE # 47)

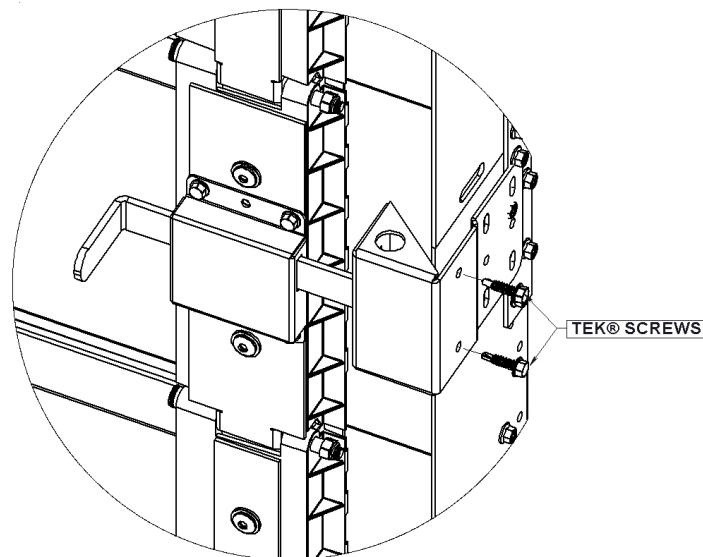

FIGURE #47. Attaching Locks and Receivers (Right Side shown).

□ Installing Header Seal Brush & Upper Track Seals

NOTE:

The Wall Header Brush Seal Assembly must maintain contact with the top panel seal in the closed or locked position. This creates the seal at the top of the door.

1. Crimp ends of the Wall Header Brush Seal Assembly to ensure brush does not come out.
2. Attach Header Brush Seal Assembly to header using Tapcon Concrete Screws. When the door is closed the wall header brush should be touching the underside of the door header seal. **(SEE FIGURE #48)**

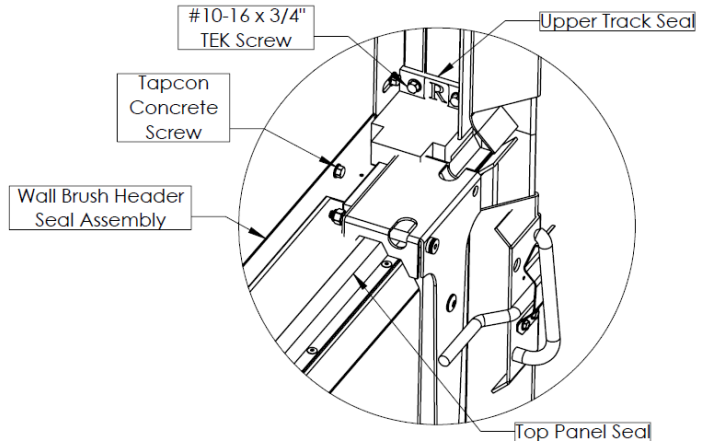

FIGURE #48.

Installing Header Seal Brush Assembly.

NOTE:

To make the installation of the Upper Track Seal easier, raise the door all the way and pull the bottom two panels out of the track towards the inside of the building. This will allow you better access to the area where the Upper Track will attach.

1. Starting on the left side of the door, locate the Upper Left Track Seal DR5431 as shown in **(FIGURE #49)**. Fasten the seal to the Mounting Rail using the supplied CP2108 #10-16 x 3/4" TEK® Screws.
2. Verify that all gaps are sealed between the door, Header Brush and wall when the door is in the closed position.
3. Repeat on other side using DR5432 (Right) Upper Track Seal.

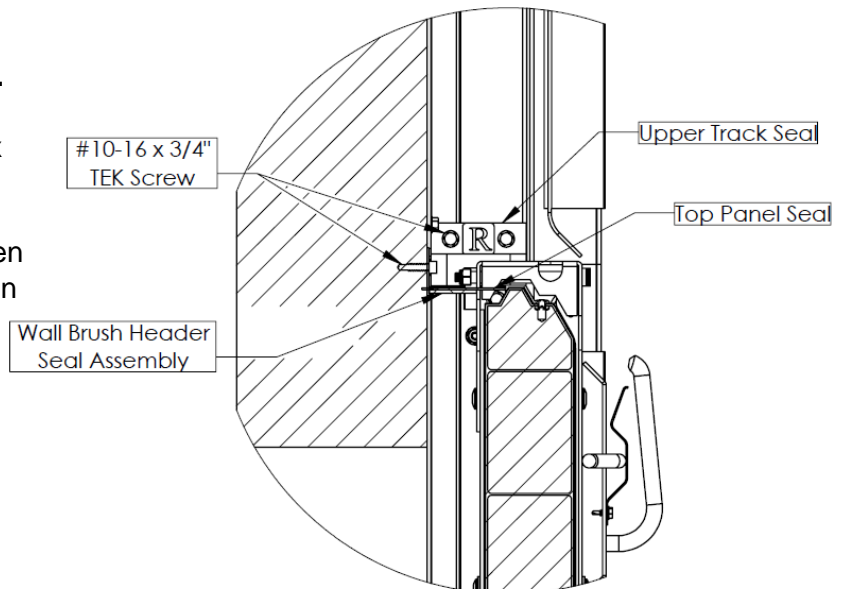

FIGURE #49.

Installing Upper Track Seal.

MxV™ Operating, Installation and Maintenance Guide

Final Door Checklist

1. Cycle door to confirm smooth, easy operation;
- Door does not drift down into door opening when fully opened.
 - Once started, door raises on its own.
 - Brush is fully seated in the brush guide of the track.
 - Door does not drift up when Hold Down Brackets are properly positioned.
 - Cable winds around drums smoothly.
 - Lubricate Springs and Bearings.

2. MxV door is sealed at all points;
- Top Side Seals are contacting the Header Seal Brush.
 - Header Seal Brush is contacting Top Panel Seal at all points.
 - Gap Flaps are properly seated in the brush guide of the track and are not pinched between panels.
 - Bottom Seal Flaps are fully seated in the brush guide of the track in the bottom corners.
 - Mounting Rails sealed against wall and no air/light gaps are visible.

NOTE:

Bottom Seal Brush may not sit completely flush with the floor upon initial installation. Typically the brush will set to the uneven contours of the floor within 24-48 hours.

3. Ensure the Mounting Rail and Bearing Assemblies are securely mounted after several cycles of operation.
4. Ensure the MxV door can be knocked out into the door jamb and reset.
- Knock door out into the door jamb.
 - Pull door back in past the door jamb.
 - Raise door slowly to reset brushes back into the door track.
5. If MxV door has lock option, ensure all locks can be engaged.

Installation Company:

Installer Name:

Date of Installation:

Jobsite Name and Location:

Installer Notes:

Fax Sheet to (315) 463-8559 ATTN: Service Department

MxV™ Operating, Installation and Maintenance Guide

□ Trouble Shooting Guide

SYMPTOM	PROBABLE CAUSE	SOLUTION
DOOR RAISES EASILY, CLOSSES HARD	A. Too much spring tension.	A. Remove spring tension.
DOOR RAISES HARD, CLOSSES EASILY	A. Not enough spring tension.	A. Add more spring tension.
DOOR OPERATES WITH TOO MUCH RESISTANCE	A. Door is not level. B. Broken spring. C. Door tracks are not plum.	A. Check cable length and adjust accordingly. B. Replace spring. C. Re-measure track spacing and adjust accordingly.
DOOR DOES NOT ENGAGE LOCK RECEIVER	A. Lock receiver hood is not properly installed.	A. Properly align lock receiver hood.
HOLD DOWN BARS DO NOT ENGAGE SPRING CLIPS PROPERLY	A. Tracks are not plum. B. Spring clip position is wrong. C. Spring plate assembly is in wrong position.	A. Re-measure track spacing and adjust accordingly. B. Re-position spring clip so that the hold down bar is in the top center of the spring clip. C. Refer to page 9 for proper location.
AIR LEAKAGE OR LIGHT SHOWING	A. Side brushes are pinched or damaged. B. Door tracks are not plum. C. Side brushes and/or gap flaps are not in the track guide. D. Gap flap is pinched between panels.	A. Check and repair side brushes. B. Re-measure track spacing and adjust accordingly. C. Reset side brushes and/or gap flaps in proper location. D. Separate panels and reset gap flap in proper position.
DOOR DOES NOT KNOCK OUT OF DOOR JAMB	A. Door tracks are not centered on door opening. B. Obstruction in door jamb.	A. Detach and re-center door tracks. B. Remove obstruction from door jamb.

MxV™ Operating, Installation and Maintenance Guide

□ MxV Maintenance Procedures

	ITEM	PROCEDURE	MAINTENANCE INTERVALS	
			6 Months	12 Months
1	Cable Drums	Check all set screws and shaft keys and securely tighten.	X	
2	Cables	Lube & check for signs of abnormal wear or damage. Inspect all cables. Replace if needed.	X	
3a	Counterweight Doors	Inspect and check cable assembly, safety cog, cable tensioning device and counterweight basket assembly. Check and securely tighten all screws. Look for signs of wear on cable.	Every 6 months	
3b	Counterweight Doors	Inspect bushing on tensioner arm for signs of wear every 6 months. Replace bushing after 15,000 cycles, or if showing signs of wear.	Every 6 months	
4	Torsion Spring Doors	Lubricate torsion spring, operate door to ensure the door clears the header. Adjust spring as necessary.	Every 6 months	
5	Seals	Check to ensure that seals aren't torn or fray.	As Needed	
6	Brush	Inspect for fraying	X	
7	End Caps/Hinges	Check for signs of abnormal wear or damage.	X	
8	Panels	Check for signs of abnormal wear or damage.		X
9	Track	Check for signs abnormal wear or damage		X
10	Track	Check for proper track spacing and alignment.		X
11	Track	Check and properly secure all track anchors.	X	
12	Track	Inspect corrective slots in tracks to ensure brush is properly resetting in track.	X	
13	Fasteners	Check and properly secure all fasteners.	X	
14	Spring Plate	Check the spring clip for proper positioning.	X	
15	Labels	Inspect all labels. Replace as needed.	X	
16	Panels	Clean with soap and hot water only. Call DL Manufacturing before using other cleaners.	As Needed	

□ Warranty Policy

NOTE: Do not paint doors. Painting door without factory written authorization will void all warranties

~ All Products (excluding bulbs) manufactured by DL Manufacturing are warranted to be free from defects for a period of 12 months from the date of shipment, excluding doors, which have a warranty period of 12 months from date of installation or 18 months from shipment, whenever occurs first.

This warranty is subject to unreasonable/improper use or use beyond rated conditions, improper storage, negligence or accident; damage because of incorporated use of equipment with Goods, after Customer has or reasonably should have, knowledge of any defect; or improperly installed by any other Person that is unauthorized by DL Manufacturing.

This warranty is subject to customer covenants to inform all subsequent buyers of the Goods of the limitation on and exclusive of warranties provided for herein. Customer hereby indemnifies and agrees to hold DL Manufacturing harmless from and against all losses, costs and expenses, including reasonable attorney's fees incurred by DL Manufacturing as a result of any third party claim relating to the purchase, sale or use of, or otherwise relating to, the Goods covered by this Agreement.

In no event shall DL Manufacturing be required to repair, replace or reimburse Customer for more than the part or material that is found to be defective and DL Manufacturing's liability shall in such event be no greater than the invoiced price of the item and shall not include labor, shipping or other costs incurred in connection with the reshipment of defective Goods to DL Manufacturing or the reinstallation of such Goods after any repair or replacement. The remedy set forth in this paragraph is expressly agreed to be the sole and exclusive remedy for any breach of warranty. This warranty is exclusive and in lieu of all other warranties expressed or implied, including but not limited to any warranty of merchantability or of fitness for a particular purpose.

Limitation of Liability - In no event as a result of breach of contract, warranty or negligence shall DL Manufacturing be liable for special, or consequential damages including but not limited to loss of profits or revenues, loss of any equipment, cost of capital, cost of substitute equipment, facilities or services, downtime costs or claims of purchasers of the Customer for such damages. Additionally, DL Manufacturing will not be liable for any delay in the performance of contracts and orders, or in the shipment and delivery of goods, or for any damage suffered by the Customer by reason of delay, when such delay is, directly or indirectly, caused by force majeure, including war, Government interference, strikes, embargoes, shortage of labor, fuel, fires, floods, or any other cause or cause whether or not similar in nature to any of those herein before specified beyond DL Manufacturing's control.